



---

CUBE ICE DISPENSER

**DIM-30DE-2**

# **SERVICE MANUAL**

# CONTENTS

# PAGE

|   |    |
|---|----|
| I. GENERAL INFORMATION -----                    | 1  |
| 1. DIMENSIONS/CONNECTIONS -----                 | 1  |
| 2. CONSTRUCTION -----                           | 3  |
| [a] OVERVIEW -----                              | 3  |
| [b] WATER CIRCUIT AND MACHINE COMPARTMENT ----- | 5  |
| II. CONTROLLER BOARD -----                      | 6  |
| 1. CONFIGURATION -----                          | 6  |
| [a] CONTROLLER BOARD LAYOUT -----               | 6  |
| [b] INPUT/OUTPUT LAYOUT -----                   | 7  |
| [c] BEFORE CHECKING CONTROLLER BOARD -----      | 8  |
| [d] SWITCH OPERATION -----                      | 9  |
| [e] VERSION COMPARISON -----                    | 11 |
| 2. OPERATION -----                              | 12 |
| [a] SOFT START -----                            | 12 |
| [b] WATER PAN OPENS -----                       | 12 |
| [c] DEFROST CYCLE -----                         | 12 |
| [d] WATER PAN CLOSES -----                      | 13 |
| [e] FREEZE CYCLE -----                          | 13 |
| [f] FREEZE COMPLETION CONTROL -----             | 14 |
| [g] WATER SUPPLY CONTROL -----                  | 17 |
| [h] AMBIENT TEMPERATURE CORRECTION -----        | 17 |
| [i] DIMPLE DIAMETER SETTING -----               | 17 |
| [j] BIN CONTROL CYCLE -----                     | 18 |
| [k] RESET SWITCH -----                          | 18 |
| [l] 7-SEGMENT LED -----                         | 18 |
| 3. MODE SETTING -----                           | 19 |
| [a] WATER CIRCUIT FLUSH MODE -----              | 19 |
| [b] MAINTENANCE MODE -----                      | 20 |
| [c] DISPLAY MODE (LOG CLEARING) -----           | 27 |
| [d] MODEL CODE SETTING MODE -----               | 28 |
| 4. 7-SEGMENT DISPLAY -----                      | 30 |
| [a] NORMAL MODE -----                           | 30 |
| [b] MAINTENANCE MODE -----                      | 30 |
| [c] DISPLAY MODE -----                          | 32 |
| 5. ERROR CODES -----                            | 33 |
| [a] ERROR CODES, CAUTION CODES -----            | 33 |
| [b] SERVICE DIAGNOSIS -----                     | 34 |
| 6. TROUBLESHOOTING -----                        | 35 |
| [a] INSTRUCTIONS FOR SERVICE ENGINEER -----     | 35 |
| [b] CHECKING CONTROLLER BOARD -----             | 35 |
| 7. REMOVAL AND REPLACEMENT -----                | 36 |
| 8. TIMING CHART -----                           | 38 |

|  |    |
|--|----|
| III. OPERATING INSTRUCTIONS-----                             | 41 |
| 1. IN CASE OF DIRTY WATER -----                              | 41 |
| 2. PREPARING THE ICE DISPENSER FOR LONG STORAGE -----        | 42 |
| IV. MAINTENANCE INSTRUCTIONS -----                           | 43 |
| 1. MACHINE EXTERIOR, SPOUT, ICE STATION-----                 | 43 |
| 2. AIR FILTER-----   | 43 |
| 3. DRAIN PAN, STORAGE BIN, FRONT PANEL (UPPER)-----          | 44 |
| 4. ICE STATION, DRAIN TRAP -----                             | 44 |
| 5. WATER VALVE-----  | 45 |
| 6. ICEMAKING WATER SYSTEM-----                               | 47 |
| V. TECHNICAL INFORMATION-----                                | 50 |
| 1. WATER CIRCUIT AND REFRIGERANT CIRCUIT-----                | 50 |
| 2. WIRING DIAGRAM -----                                      | 51 |
| 3. PERFORMANCE DATA-----                                     | 52 |
| VI. SERVICE DIAGNOSIS -----                                  | 53 |
| 1. NO ICE PRODUCTION -----                                   | 53 |
| 2. LOW ICE PRODUCTION-----                                   | 55 |
| 3. ABNORMAL ICE -----  | 55 |
| 4. OTHERS-----   | 56 |
| VII. REMOVAL AND REPLACEMENT OF COMPONENTS -----             | 57 |
| 1. PANELS-----   | 57 |
| [a] FRONT PANEL (UPPER) (serial number: K0 or earlier)-----  | 57 |
| [b] FRONT PANEL (LOWER) (serial number: K0 or earlier) ----- | 57 |
| [c] FRONT PANEL (serial number: K1 or later)-----            | 57 |
| [d] TOP PANEL -----  | 58 |
| [e] AIR GUIDE-----   | 58 |
| [f] REFRIGERATOR COVERS-----                                 | 58 |
| [g] SWITCH BOX-----  | 59 |
| 2. SERVICE FOR REFRIGERANT LINES -----                       | 60 |
| [a] SERVICE INFORMATION -----                                | 60 |
| [b] REFRIGERANT RECOVERY -----                               | 61 |
| [c] EVACUATION AND RECHARGE -----                            | 61 |
| 3. COMPRESSOR-----   | 62 |
| 4. DRIER -----   | 63 |
| 5. EVAPORATOR -----  | 64 |
| 6. HOT GAS VALVE-----  | 65 |
| 7. WATER PAN ASSEMBLY -----                                  | 66 |
| 8. PUMP MOTOR-----   | 67 |
| 9. WATER VALVE-----  | 67 |
| 10. ACTUATOR MOTOR -----                                     | 68 |
| 11. CAM ARM -----  | 69 |
| [a] CAM ARM (A) - ACTUATOR MOTOR SIDE -----                  | 69 |
| [b] CAM ARM (B) - REAR SIDE -----                            | 69 |

|  |    |
|--|----|
| 12. CONTROLLER BOARD -----                 | 71 |
| [a] MODIFICATION -----                     | 71 |
| [b] REPLACEMENT -----                      | 72 |
| 13. THERMISTOR FOR CUBE CONTROL-----       | 73 |
| 14. FAN MOTOR -----                        | 74 |
| 15. GEAR MOTOR-----                        | 74 |
| 16. BIN CONTROL SWITCH -----               | 75 |
| 17. PUSH BUTTON SWITCH AND PILOT LAMP----- | 76 |

# I. GENERAL INFORMATION

## 1. DIMENSIONS/CONNECTIONS

Auxiliary code: K0 or earlier

|                          |  |
|--------------------------|--|
| ITEM                     | Hoshizaki Cube Ice Dispenser   |
| MODEL                    | DM-30DE-2  |
| POWER SUPPLY             | 1 Phase 220-240/230V/50/60HZ<br>Capacity: 0.6kVA (2-1A)/0.58kVA (2-0A)   |
| AMPERAGE                 | Running: 2.1/1.8A Rated Motor: 2.1/1.8A<br>Starting: 13/15A  |
| ELECTRIC CONSUMPTION     | Rated Motor: 320/340W (Power factor: 63/79%)<br>Approx. 40/42kg (Ambient Temp. 10°C, Water Temp. 10°C)<br>Approx. 36/36kg (Ambient Temp. 21°C, Water Temp. 15°C)<br>Approx. 28/30kg (Ambient Temp. 32°C, Water Temp. 21°C) |
| ICE PRODUCTION PER 24H   | Approx. 0.61kg/27 pcs.<br>(Ambient Temp. 32°C, Water Temp. 21°C)   |
| ICE PRODUCTION PER CYCLE | Approx. 15kg<br>(Ambient Temp. 32°C, Water Temp. 21°C)   |
| SHAPE OF ICE             | Approx. 15kg<br>(Ambient Temp. 32°C, Water Temp. 21°C)   |
| ICE PRODUCTION PER 24H   | Approx. 0.10/0.11m <sup>3</sup> (Ambient Temp. 10°C, Water Temp. 10°C)<br>Approx. 0.09/0.09m <sup>3</sup> (Ambient Temp. 21°C, Water Temp. 15°C)<br>Approx. 0.06/0.09m <sup>3</sup> (Ambient Temp. 32°C, Water Temp. 21°C) |
| ICE RELEASE CAPACITY     | Approx. 1700g/min  |
| ICE RELEASE CAPACITY     | 350mm(W) x 526mm(D) x 150(-163)mm(H)   |
| ICE RELEASE CAPACITY     | 600/630W / 520/540kcal/h (AT: 32°C, WT: 21°C)  |
| HEAT REJECTION           | Plastic (Delivery Stage, Lower)<br>Colored Steel (Top, Side) Galvanized Steel (Rear)<br>Acrylic Painted Steel (Front)  |
| CABINET                  | ABS Plastic, Insulation: Polyurethane Foam   |
| STORAGE BIN              | Cell Type  |
| ICE MAKING SYSTEM        | Hot Gas Defrost  |
| HARVESTING SYSTEM        | Auger Operated By Push Switch  |
| DEFENSING SYSTEM         |  |
| CONNECTIONS              | X-type Con. (with CONT./UK Plug)<br>-ELECTRIC Inlet Rc1/2 (rear side)<br>-WATER SUPPLY Inlet Rc1/2 (rear side)<br>-DRAIN Outlet R3/4 (rear side)   |
| COMPRESSOR               | Hermetic   |
| EVAPORATOR               | Fin and Tube Type Air-cooled   |
| ICE MAKING CONTROL       | Electroless Nickel Plated Copper Tube on Sheet and Cells   |
| REFRIGERANT              | Capillary Tube   |
| ICE MAKING CONTROL       | R134a/200g   |
| HARVESTING CONTROL       | Thermistor, Timer  |
| ICE MAKING WATER CONTROL | Thermistor   |
| BIFF CONTROL             | Timer, Water Pan's movement  |
| PROTECTION               | Microswitch With Time Delay  |
| COMPRESSOR PROTECTION    | Class / Appliance, 5A Fuse   |
| ADJUSTABLE LEGS          | Auto-reset Overload Protector  |
| NET WEIGHT               | ABS (90-155mm)   |
| PACKAGE                  | 65kg (Gross Weight 71kg)<br>450(W) x 670(D) x 763(H)mm   |
| ACCESSORIES              | Mounting Brace (Wall Mounting), Installation Kit   |
| OPTIONAL PARTS           | Mounting Brace (Floor Mounting)  |
| OPERATING CONDITIONS     | Ambient Temp.: 1 - 40°C, Water Supply Pressure: 5 - 35°C<br>Water Supply Pressure: 0.07 - 0.78MPa (0.7 - 7.8bar),<br>Voltage Range: Rated Voltage ±10%   |

\*We reserve the right to make changes in specifications and design without prior notice.

1. Install the ice maker properly in accordance with the instructions on location, water supply/drain connections and electrical connections stated in the instruction manual provided.  
Allow 10mm extra space at the installation site to meet any installation requirements (additional spacing is also required for proper air flow and pipe connections).  
The ice production depends on the ambient and water temperatures.  
Refer to the instruction manual.
2. The adjustable legs are optional.  
Consult with our sales staff.
3. The product code: E2HA-D010

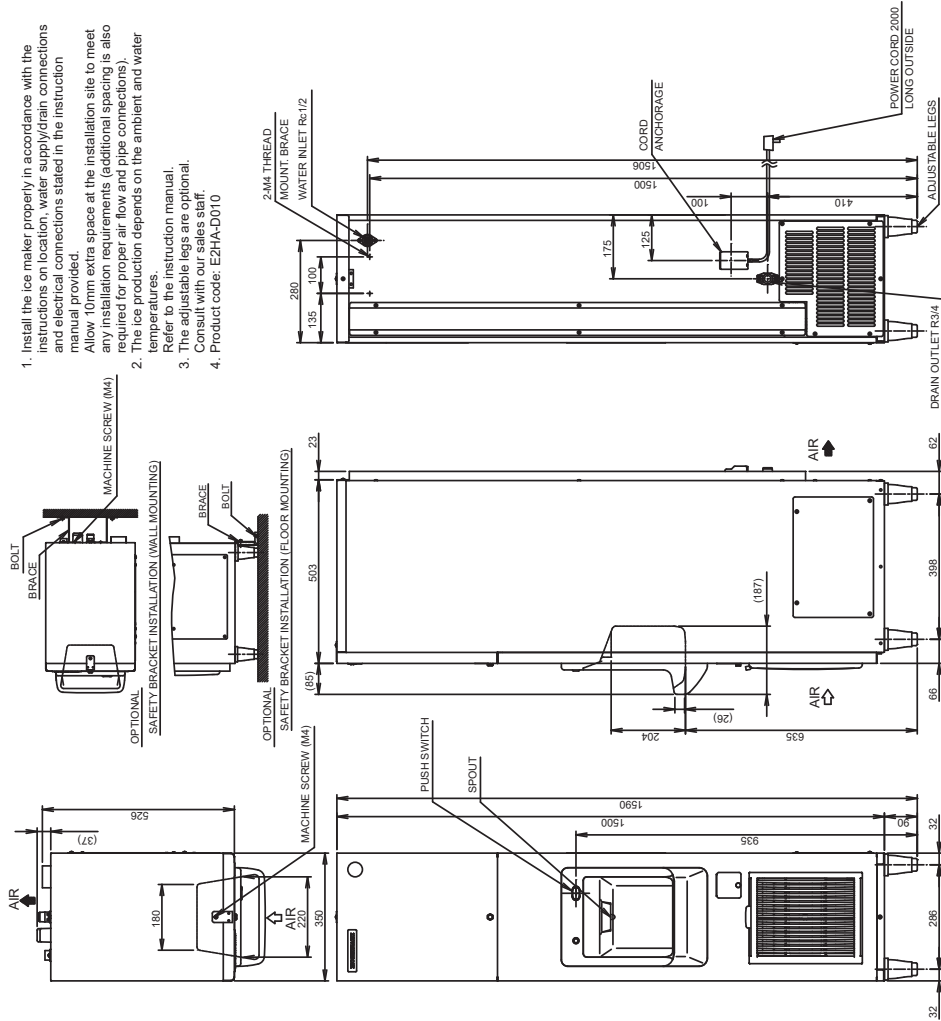

# Auxiliary code : K1 or later

|  |  |                                  |  |
|--|--|----------------------------------|--|
| <b>OPERATING CONDITIONS</b>  | Ambient Temp: 1 – 40° C, Water Supply Pressure: 5 – 35C<br>Water Supply Pressure: 0.07 – 0.78MPa (0.7 – 7.8bar)<br>Voltage Range: Rated Voltage $\pm 6/10\%$ | <b>ITEM</b>                      | Hoshizaki Cube Ice Dispenser   |
| <b>*We reserve the right to make changes in specifications and design without prior notice.</b>  |  | <b>MODEL</b>                     | DIM – 30DE – 2   |
| <b>1. Install the ice maker properly in accordance with the instructions on location, water supply/drain connections and electrical connections stated in the instruction manual provided.</b> |  | <b>POWER SUPPLY</b>              | 1 Phase 220–240/230V 50/60Hz<br>Capacity: 0.6kVA (2.1A)/0.58kVA (2.0A)   |
| <b>2. Allow 10mm extra space at the installation site to meet any installation requirements (additional spacing is also required for proper air flow and pipe connections).</b>                |  | <b>AMPERAGE</b>                  | Running: 2.1/1.8A Rated Motor: 2.1/1.8A<br>Starting: 13/13A  |
| <b>3. Refer to the instruction manual.</b>   |  | <b>ELECTRIC CONSUMPTION</b>      | Rated Motor: 320/340W (Power factor: 63/79%)   |
| <b>4. Consult with our sales staff.</b>  |  | <b>ICE PRODUCTION PER 24h</b>    | Approx. 40/42kg (AT: 10° C, WT: 10° C)<br>Approx. 36/36kg (AT: 21° C, WT: 15° C)<br>Approx. 28/30kg (AT: 32° C, WT: 21° C)   |
| <b>Product code: E2HA–D010</b>   |  | <b>SHAPE OF ICE</b>              | Cube Approx. 28x28x32mm  |
|  |  | <b>ICE PRODUCTION PER CYCLE</b>  | Approx. 0.61kg/27 pes.   |
|  |  | <b>MAX. STORAGE CAPACITY</b>     | Approx. 15kg   |
|  |  | <b>WATER CONSUMPTION PER 24h</b> | Approx. 0.15/0.17m <sup>3</sup> (AT: 10° C, WT: 10° C)<br>Approx. 0.10/0.11m <sup>3</sup> (AT: 21° C, WT: 15° C)<br>Approx. 0.08/0.09m <sup>3</sup> (AT: 32° C, WT: 21° C) |
|  |  | <b>ICE RELEASE CAPACITY</b>      | Approx. 1700g/min  |
|  |  | <b>OUTSIDE DIMENSIONS</b>        | 350mm(W) x 526mm(D) x 1590(–1635) mm(H)  |
|  |  | <b>HEAT REJECTION</b>            | 600/630W (520/540kcal/h) (AT: 32° C, WT: 21° C)  |
|  |  | <b>CABINET</b>                   | Plastic (Delivery Stage, Louver)<br>Colored Steel (Top Side) Galvanized Steel (Rear)   |
|  |  | <b>STORAGE BIN</b>               | Acrylic Painted Steel (Front)  |
|  |  | <b>ICE MAKING SYSTEM</b>         | Cell Type  |
|  |  | <b>HARVESTING SYSTEM</b>         | Hot Gas Defrost  |
|  |  | <b>ICE DISPENSING SYSTEM</b>     | Auger Operated By Push Switch  |
|  |  | <b>CONNECTIONS</b>               | X – type Con. (with CONT./UK Plug)   |
|  |  | <b>– ELECTRIC</b>                |  |
|  |  | <b>– WATER SUPPLY</b>            | Inlet G3/4 (rear side)   |
|  |  | <b>CONNECTIONS-DRAIN</b>         | Outlet R3/4 (rear side)  |
|  |  | <b>COMPRESSOR</b>                | Hermetic   |
|  |  | <b>CONDENSER</b>                 | Fin and Tube Type, Air-cooled  |
|  |  | <b>EVAPORATOR</b>                | Electroless nickel plated Copper Tube on Sheet   |
|  |  | <b>REFRIGERANT CONTROL</b>       | Capillary Tube   |
|  |  | <b>REFRIGERANT</b>               | R134a/200g   |
|  |  | <b>ICE MAKING CONTROL</b>        | Thermistor, Timer  |
|  |  | <b>HARVESTING CONTROL</b>        | Thermistor   |
|  |  | <b>ICE MAKING WATER CONTROL</b>  | Timer, Water Pan's movement  |
|  |  | <b>BIN CONTROL</b>               | Microswitch With Time Delay  |
|  |  | <b>ELECTRICAL PROTECTION</b>     | Class I Appliance, 5A Fuse   |
|  |  | <b>COMPRESSOR PROTECTION</b>     | Auto – reset Overload Protector  |
|  |  | <b>ADJUSTABLE LEGS</b>           | ABS (90 – 135mm)   |
|  |  | <b>NET WEIGHT</b>                | 65kg (Gross: 80kg)   |
|  |  | <b>PACKAGE</b>                   | 450(W) x 730(D) x 1666(H) mm   |
|  |  | <b>ACCESSORIES</b>               | Mounting Brace (Wall Mounting), Installation Kit   |
|  |  | <b>OPTIONAL PARTS</b>            | Mounting Brace (Floor Mounting)  |

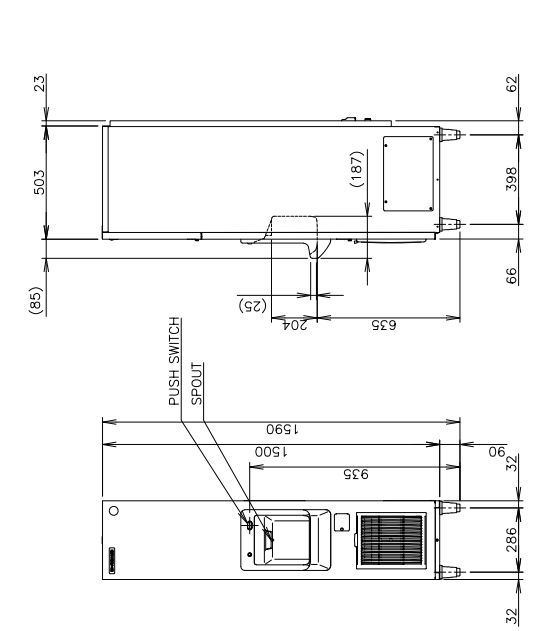
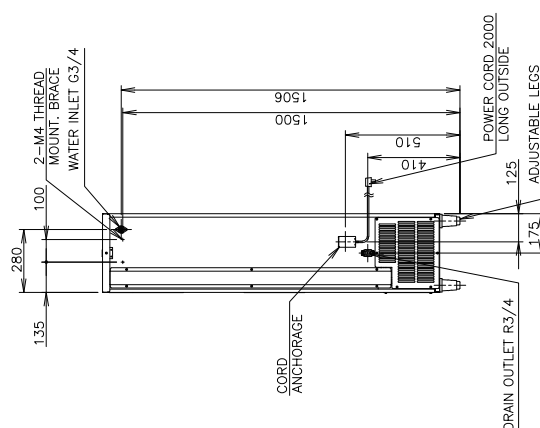
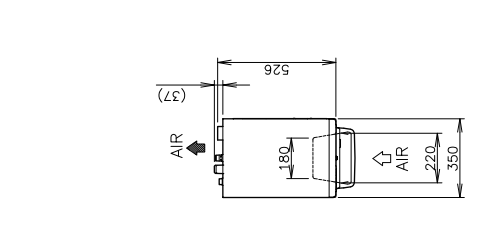
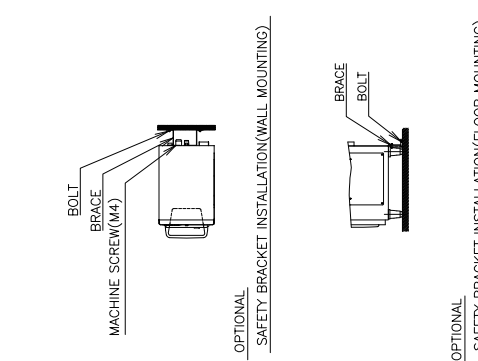

## 2. CONSTRUCTION

### [a] OVERVIEW

Auxiliary code: K0 or eariler

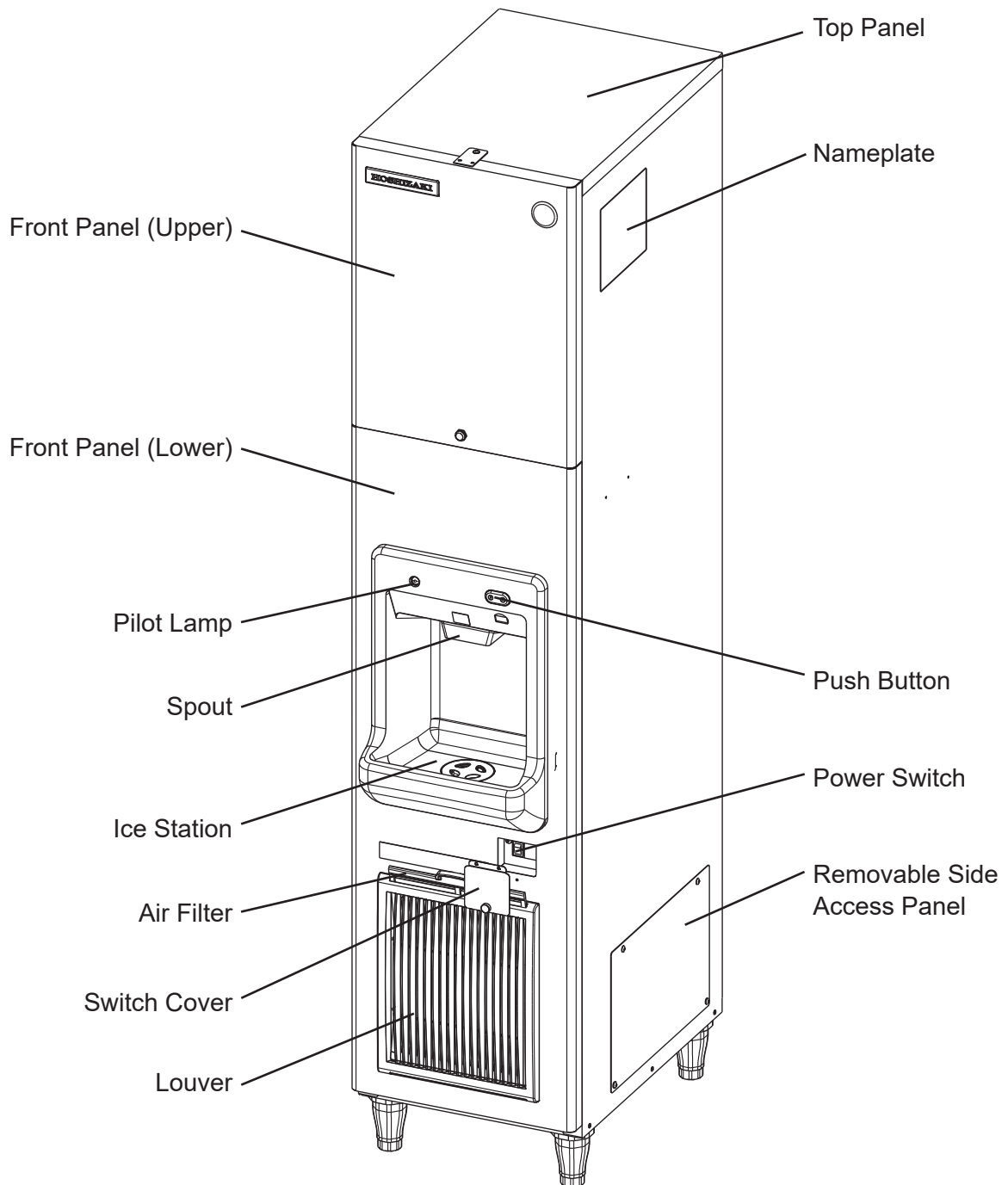

Auxiliary code : K1 or later

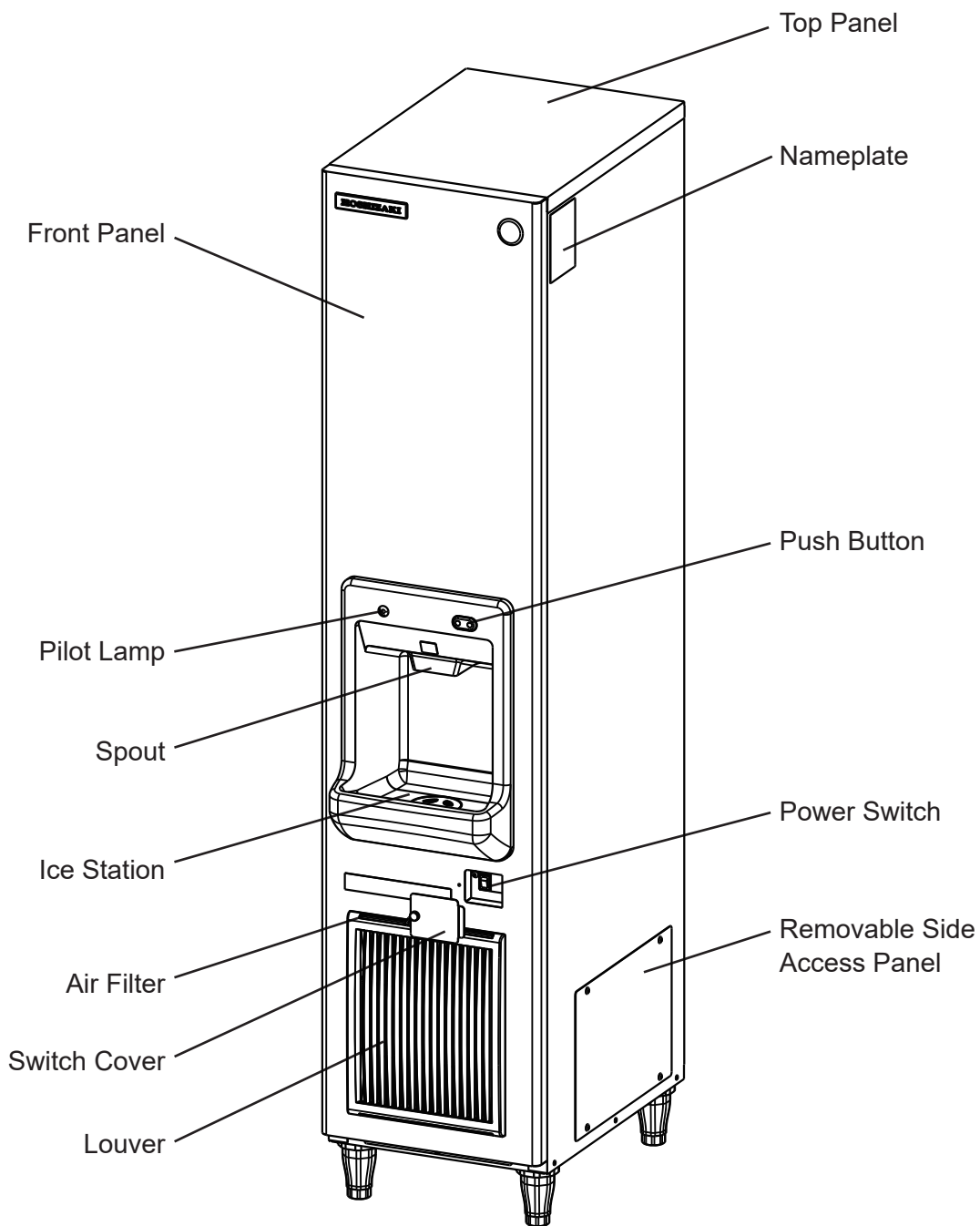



**[b] WATER CIRCUIT AND MACHINE COMPARTMENT**

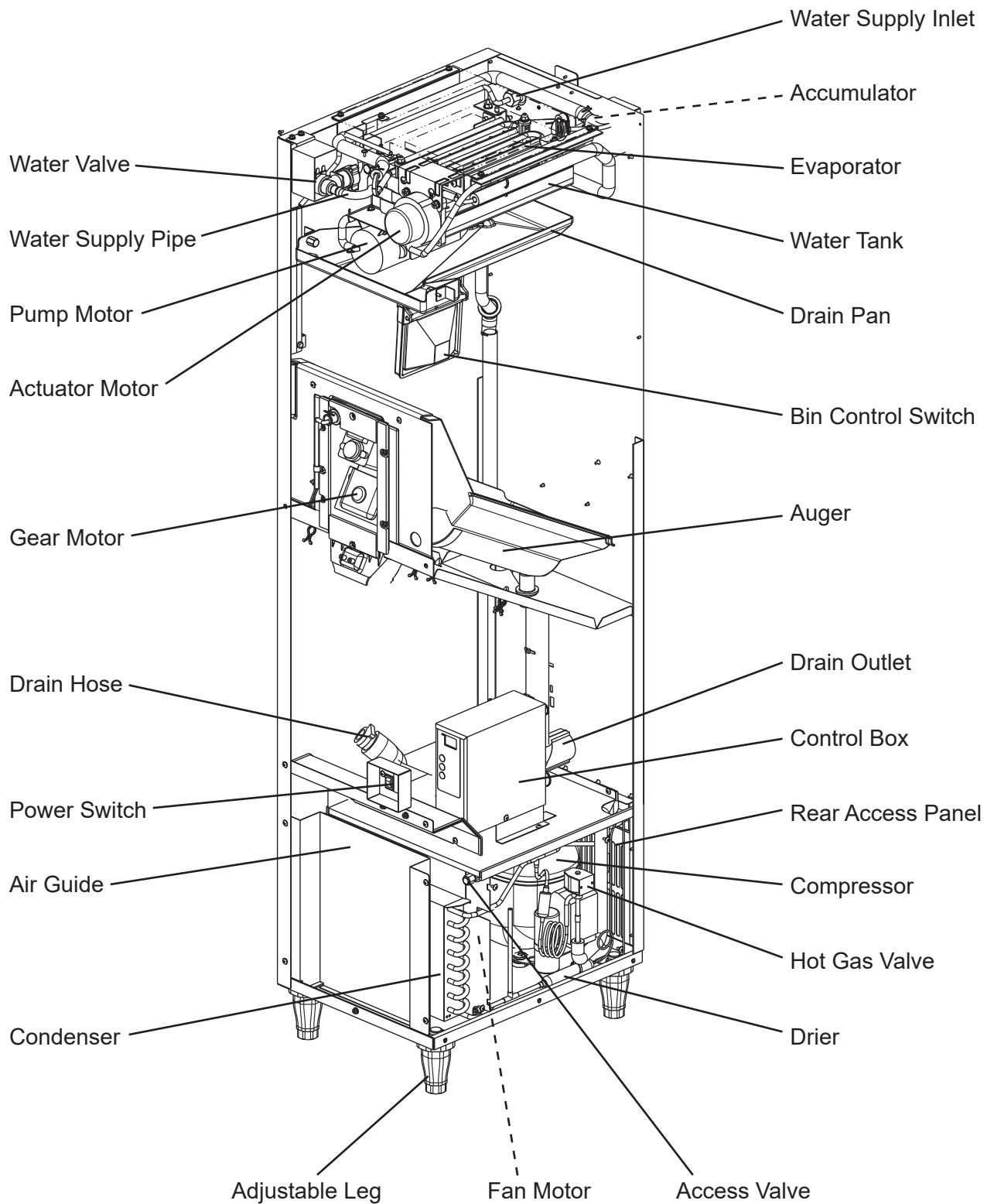

## II. CONTROLLER BOARD

### 1. CONFIGURATION

|             |            |                           |
|-------------|------------|---------------------------|
| Part Number | P01873-01  | P01873-02                 |
| Evaporator  | Tin plated | Electroless nickel plated |

#### [a] CONTROLLER BOARD LAYOUT

Main Board

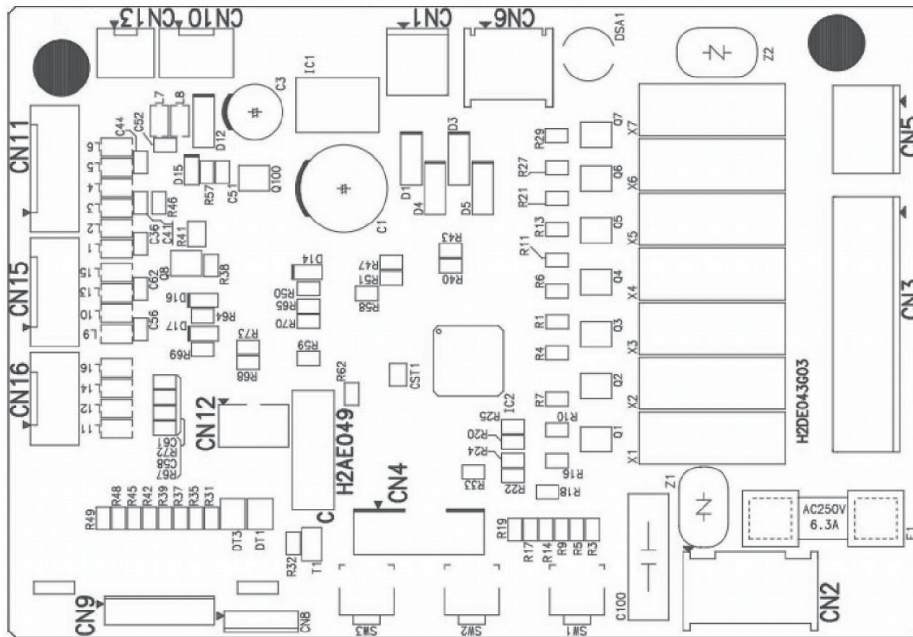

Sub Board

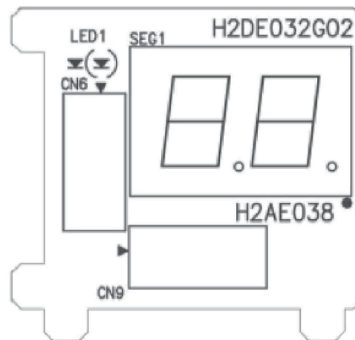

Combination

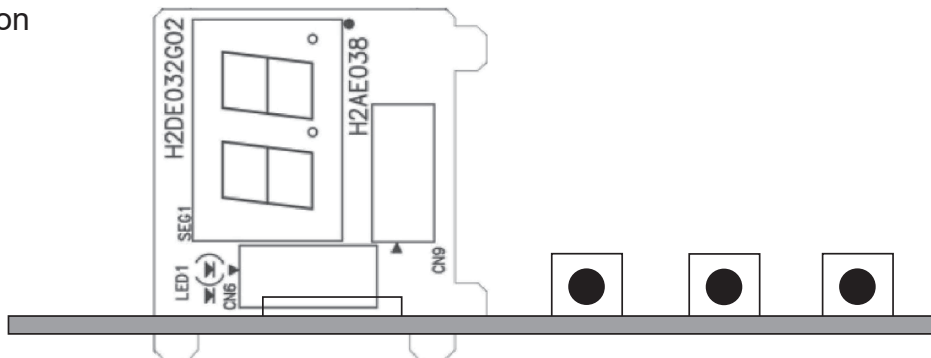

# [b] INPUT/OUTPUT LAYOUT

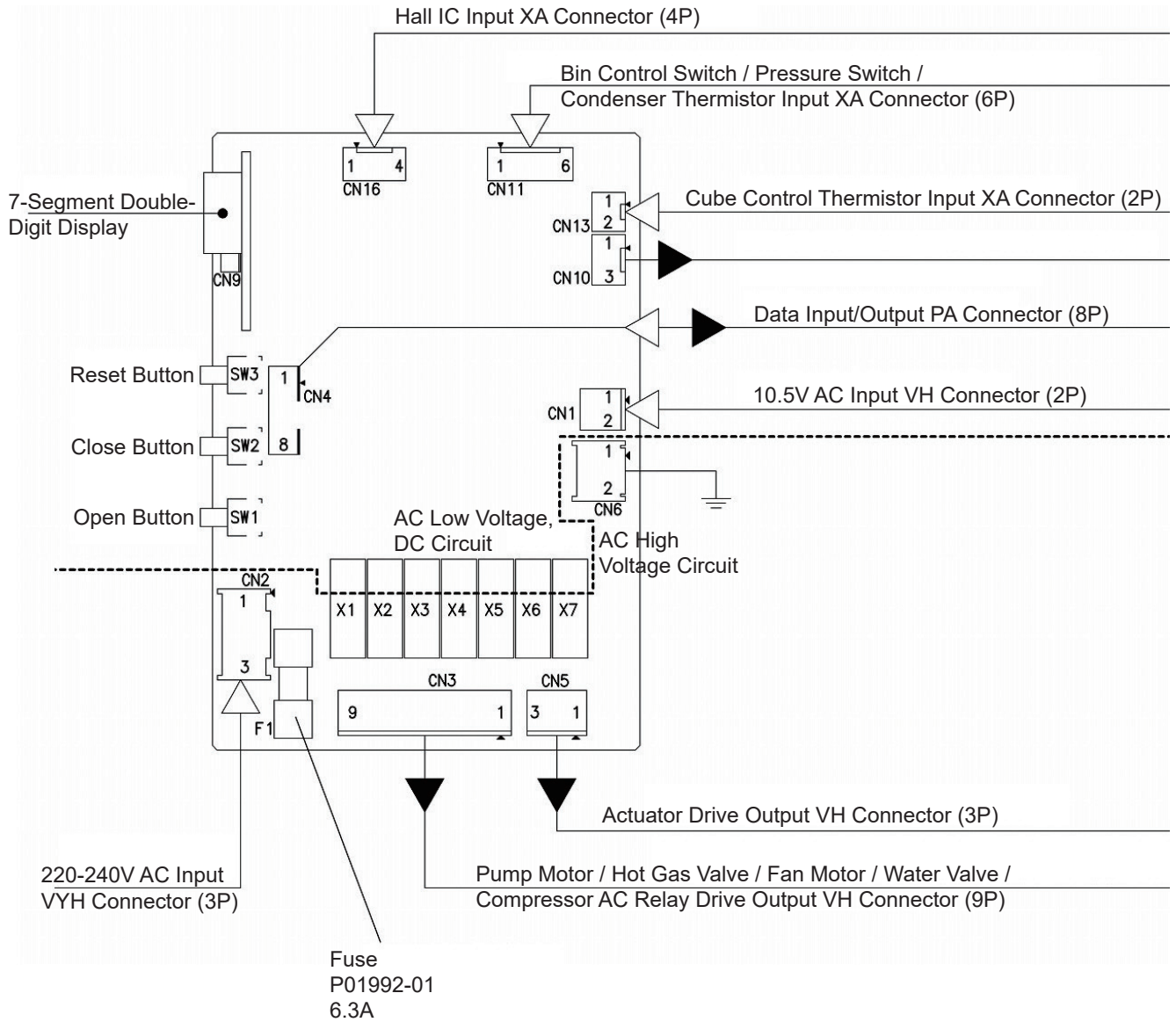

**[c] BEFORE CHECKING CONTROLLER BOARD**

Check the power source voltage and the components as shown in the table below.

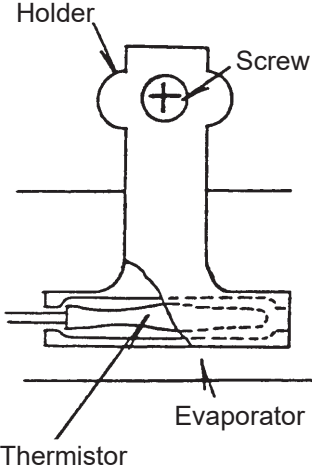
| Component  | Procedure   | Normal  |
|--|---|---|
| <p>1. Thermistor<br/>(on evaporator)</p>  | <div style="border: 1px solid black; padding: 5px; text-align: center; margin-bottom: 10px;"> <p><b>NOTICE</b></p> <p>Thermistor sensor part is fragile, glass sealed. Handle with care.</p> </div> <ul style="list-style-type: none"> <li>* Disconnect the connector CN13 on the board.</li> <li>* Remove the screw and the thermistor holder on the evaporator.</li> <li>* Immerse the sensor part in a glass containing ice and water for 5 minutes.</li> <li>* Check the resistance between CN13 connector pins.</li> <li>* Replace the thermistor in its correct position.</li> <li>* Connect CN13.</li> </ul> | <p>5 -7 kilohms</p>   |
| <p>2. Bin Control Switch</p>   | <p>Manually set the micro switch in the TRIP and RESET positions, and check the period.</p>   | <p>Approx.<br/>TRIP (Closed) 10 sec.<br/>RESET (Open) 80 sec.</p> |

## [d] SWITCH OPERATION

- 1) The following is the switch operation flow in different modes. When pressed and released, the switch detects the operation by its pressing duration.

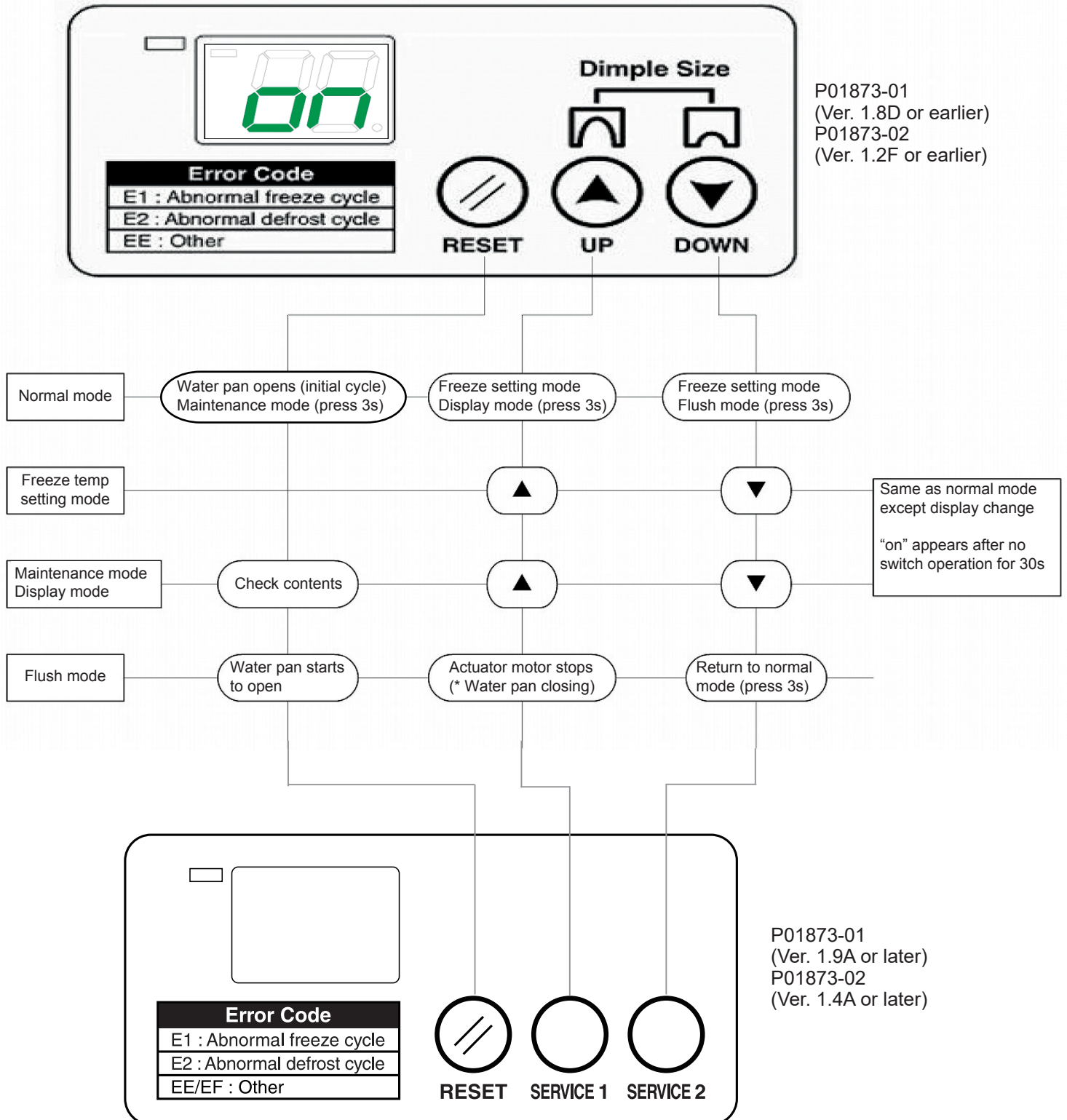

2) To clear the current model code information and enter the model setting mode, press the up and down switches together for 15 seconds while the model code is indicated in the display mode (see “3. [c] DISPLAY MODE”).

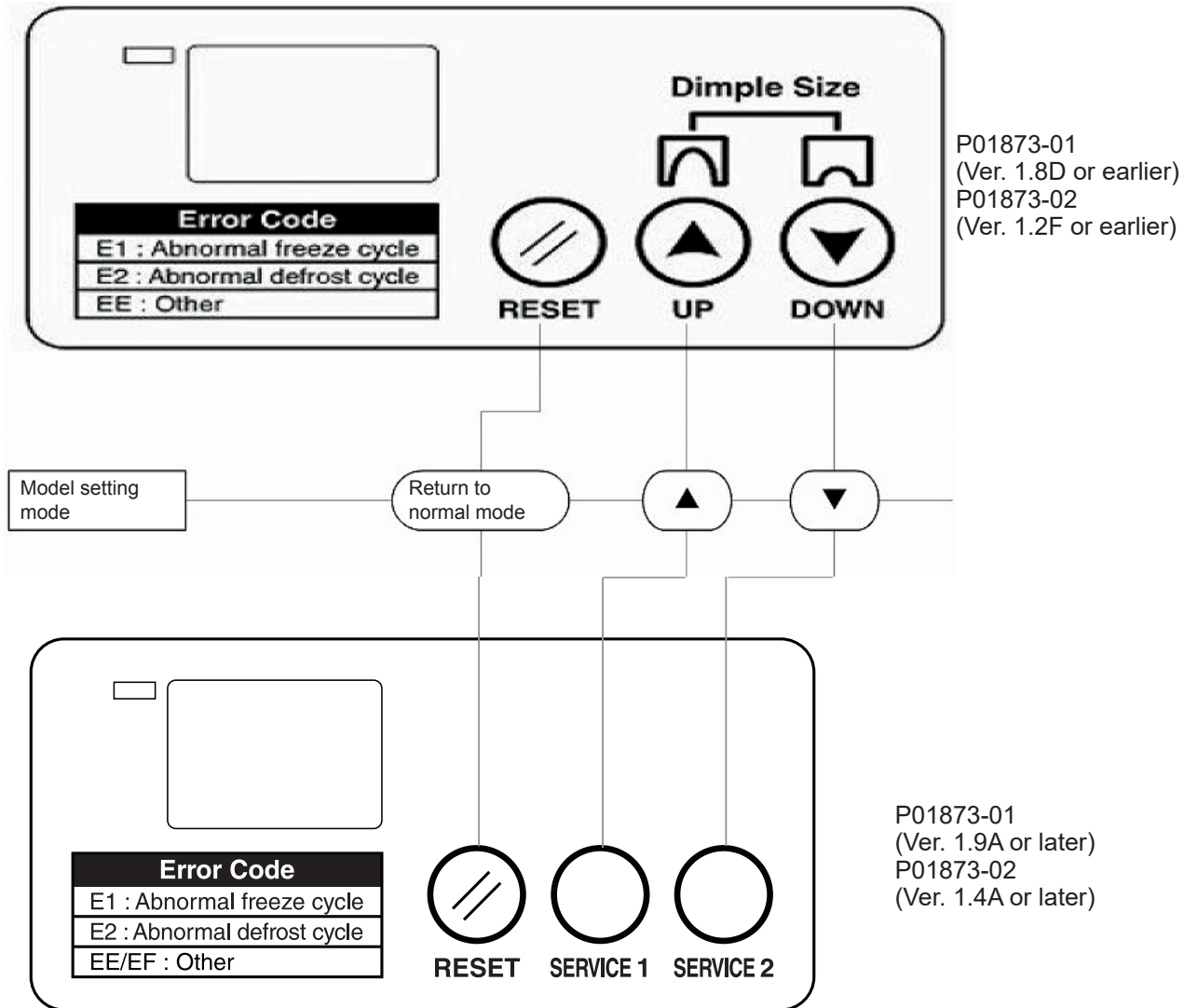

## [e] VERSION COMPARISON

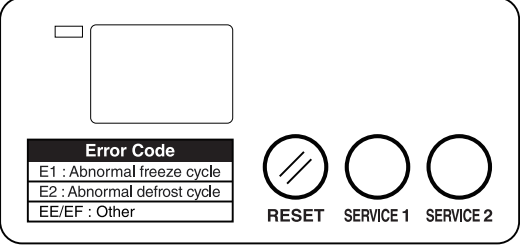
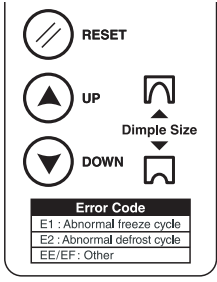
|                  |   |   |
|------------------|---|---|
| Operator         | P01873-01 (Ver. 1.9A or later),<br>P01873-02 (Ver. 1.4A or later)   | P01873-01 (Ver. 1.8D or earlier),<br>P01873-02 (Ver. 1.2F or earlier)   |
| End-user         | <ul style="list-style-type: none"> <li>Control mode: Normal</li> <li>No. 2: Target integrated freeze completion temperature <b>cannot be changed</b>.</li> <li>Target integrated freeze completion temperature <b>cannot be changed</b> by pressing "SERVICE 1" or "SERVICE 2" button on control panel</li> <li>* Control label has been changed.</li> </ul>   | <ul style="list-style-type: none"> <li>Control mode: Normal</li> <li>No. 2: Target integrated freeze completion temperature <b>can be changed</b>.</li> <li>Target integrated freeze completion temperature <b>can be changed</b> every 0.5°C by pressing "▲UP" or "▼DOWN" button on control panel.</li> <li>Change range: <b>-5°C to -40°C</b></li> </ul>   |
| Service engineer | <ul style="list-style-type: none"> <li>Control mode: Maintenance mode</li> <li>Press and hold "RESET" button for more than 3 seconds to show setting number "1".</li> <li>Select desired number with "SERVICE 1(▲)" or "SERVICE 2(▼)".</li> <li>Press "RESET" button to flash set value on display.</li> <li>Change set value with "1(▲)" or "2(▼)".</li> <li>Press "RESET" button to memorize set value and return to setting number.</li> <li>Leave buttons untouched for 30 sec to shift to normal mode.</li> <li>All settings are adjustable.</li> <li>Adjustable range: <b>Nos. 2 and 3 have additional setting ranges.</b></li> </ul> <p>No. 2: Target integrated freeze completion temperature<br/><b>Factory setting ± 3°C</b> * every 0.5°C</p> <p>No. 3: Target integrated freeze completion time<br/><b>Factory setting ± 2 min</b> * every 1 min</p> <p>* <b>Factory settings cannot be changed, but set values can be changed within the above setting ranges.</b></p> | <ul style="list-style-type: none"> <li>Control mode: Maintenance mode</li> <li>Press and hold "RESET" button for more than 3 seconds to show setting number "1".</li> <li>Select desired number with "▲" or "▼".</li> <li>Press "RESET" button to flash set value on display.</li> <li>Change set value with "▲" or "▼".</li> <li>Press "RESET" button to memorize set value and show setting number.</li> <li>Leave buttons untouched for 30 sec to shift to normal mode.</li> <li>All settings are adjustable.</li> <li>Adjustable range: e.g. Nos. 2 and 3</li> <li>No. 2: Target integrated freeze completion temperature<br/><b>-5 to -40°C</b> * every 0.5 °C</li> <li>No. 3: Target integrated freeze completion time<br/><b>5 to 90 min</b> * every 1 min</li> <li>* <b>Factory settings can be changed.</b></li> </ul> |



|  |  |   |
|--|--|---|
| Setting number   | P01873-01 (Ver. 1.9A or later),<br>P01873-02 (Ver. 1.4A or later)              | P01873-01 (Ver. 1.8D or earlier),<br>P01873-02 (Ver. 1.2F or earlier) |
| No. 71<br>Hot gas valve ON time to<br>prevent ice stuck  | Setting range: 0 to <b>10</b> sec<br>* every 1 sec                             | Setting range: 0 to <b>20</b> sec<br>* every 1 sec                    |
| No. 72<br>Hot gas valve OFF time to<br>prevent ice stuck | <b>Not adjustable</b><br><b>OFF time = 30 sec – No. 71 set<br/>value (sec)</b> | <b>Setting range: 0 to 60 sec</b><br><b>* every 1 sec</b>             |

## 2. OPERATION

This service manual specifies the basic operation of the controller board “Ver. 1.0A”.

### [a] SOFT START

- 1) When the power supply is turned on, the 7-segment LED shows “on” and the hot gas valve opens. After 30 seconds, the defrost cycle starts.
  - \* If the reset switch is pressed during the 30-second standby time, the unit resets soft start and immediately starts operation.

### [b] WATER PAN OPENS

- 1) The hot gas valve opens, the actuator motor starts, and the water pan starts to open.
- 2) After 20 seconds, the water valve opens to supply defrosting water (water pan cleaning water) for a specific time.
  - \* The defrosting water supply time varies between the water temperatures above and below 13°C.
  - \* In the initial cycle, the water temperature is not detected and assumed to be below 13°C, resulting in a longer defrosting water supply time.
  - \* The defrosting water supply time is adjustable in the maintenance mode (see “3. [b] MAINTENANCE MODE”).
- 3) The opening backup timer starts counting when the water pan starts to open. If the hall IC does not turn on within 3 minutes, the display shows “EE” and the unit stops for 60 minutes. If the error recurs after the unit resumes operation, the display shows “EE” and the unit shuts down (recorded as “E3” in error history).

### [c] DEFROST CYCLE

- 1) After the water pan opens, the hot gas valve opens until the defrost completion temperature is reached.
- 2) If the defrost completion temperature is not reached even when the defrost backup timer counts up (30 minutes after water pan starts to open), the display shows “E2” and the unit stops.
  - If the hot gas valve fails to open, the unit may stop with the “E2” error.



- \* The defrost completion temperature is adjustable in the maintenance mode (see “3. [b] MAINTENANCE MODE”).

#### **[d] WATER PAN CLOSES**

- 1) When the cube control thermistor senses the evaporator temperature above the defrost completion temperature, the hot gas valve closes, the fan motor starts, and the water pan starts to close.
- 2) The closing backup timer starts counting when the water pan starts to close. If the hall IC does not turn on within 3 minutes, the display shows “EE” and the unit stops for 60 minutes. If the error recurs after the unit resumes operation, the display shows “EE” and the unit shuts down (recorded as “E4” in error history).
  - \* In the initial cycle or when the water temperature is below 13°C, the water valve opens to supply defrosting water for 10 seconds after the water pan starts to close.

#### **[e] FREEZE CYCLE**

- 1) When the water pan closes and the hall IC turns on, the water valve opens to supply icemaking water for a specific time. The icemaking water supply time varies between startup, reset, and the end of bin control cycle.
  - \* The icemaking water supply time and additional water supply time are adjustable in the maintenance mode (see “3. [b] MAINTENANCE MODE”).
- 2) After icemaking water has been supplied, the pump motor starts.
- 3) After 30 seconds, the cube control thermistor senses the temperature that will be added with a predetermined offset value and used as the water temperature in the freeze cycle, water pan opening cycle, defrost cycle, and water pan closing cycle.
  - \* The offset value for the cube control thermistor temperature is adjustable in the maintenance mode (see “3. [b] MAINTENANCE MODE”).
- 4) The freeze cycle is considered to be 100% complete when the predetermined target integrated values are reached.
  - \* The target integrated values (temperature and time) for the freeze completion are adjustable in the maintenance mode (see “3. [b] MAINTENANCE MODE”).
- 5) To reduce ice forming on the water pan when the freeze completion rate reaches 100% at an ambient temperature below 30°C, the hot gas valve opens and closes two times for a specific time to raise the water pan temperature. Then, the actuator motor starts to open the water pan.

While the hot gas valve opens and closes, the freeze cycle is not considered to be complete and the pump motor and fan motor keep running.

  - \* The ambient temperature setting and hot gas valve opening/closing time are adjustable in the maintenance mode (see “3. [b] MAINTENANCE MODE”).
- 6) Even if the freeze backup timer counts up (45/60 minutes after water pan starts to close), the unit stops with the “E1” error when the evaporator temperature is above 0°C.

If the hot gas valve fails to close, the unit may stop with the “E1” error.

  - \* The backup timer setting is adjustable in the maintenance mode (see “3. [b] MAINTENANCE MODE”).

## [f] FREEZE COMPLETION CONTROL

- 1) The target integrated values (cube control thermistor temperature and freeze cycle time) are set for freeze completion.
  - \* The target integrated freeze completion temperature and time are adjustable in the maintenance mode (see “3. [b] MAINTENANCE MODE”).
- 2) After the cube control thermistor senses a temperature below 0°C, the cube control thermistor temperature and freeze cycle time are integrated every second.
- 3) When the integrated values reach the target, the freeze cycle completes.

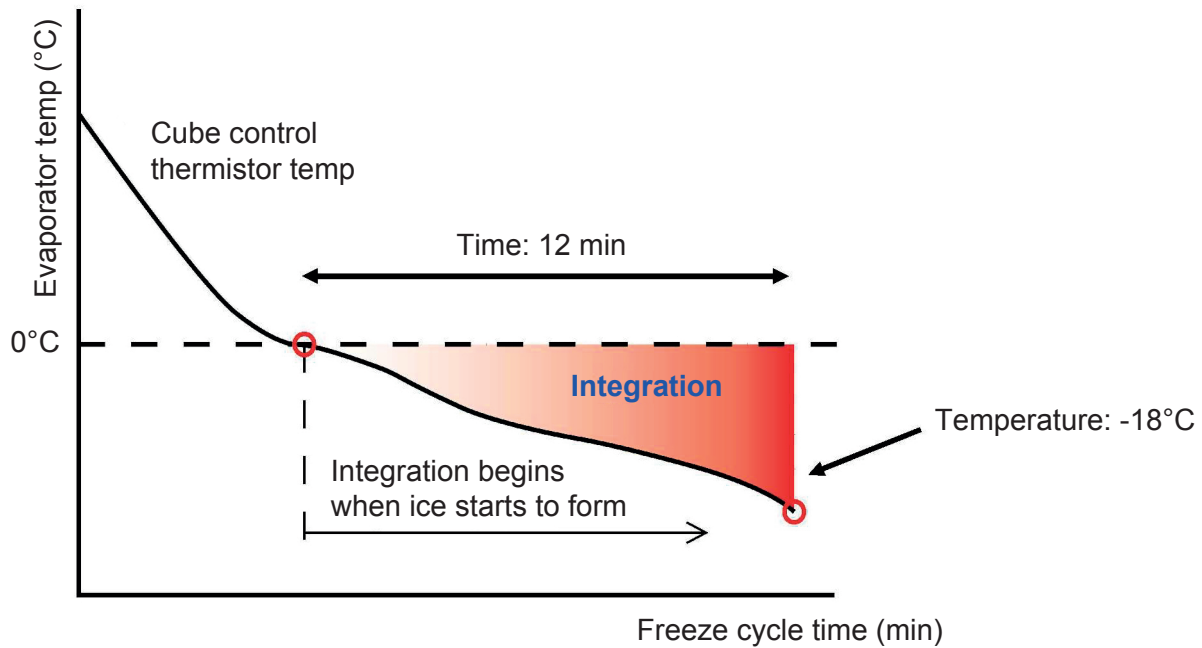

As the previous freeze completion control depended on the freeze completion temperature only, the dimple size varied in 1) spring/fall, 2) summer, and 3) winter even at the same freeze completion temperature.

For example, when the freeze completion temperature is -18°C and the dimple size is 5 mm, the freeze cycle time becomes longer and dimple size smaller in summer, and the freeze cycle time becomes shorter and dimple size larger in winter.

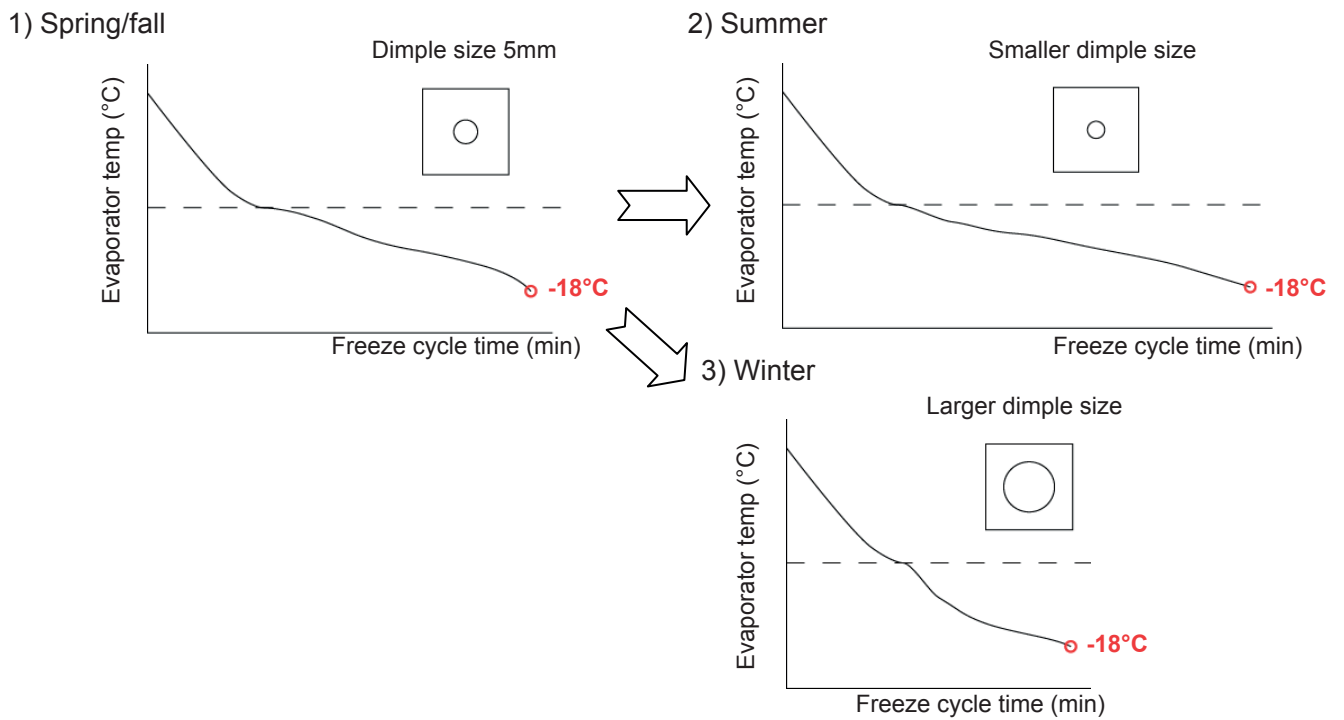

Comparison of the evaporator temperature curves finds that the red-colored area varies in different seasons.

Note: It is assumed that the water temperature is the same in these examples as the time to reach the zero degrees mark is different.

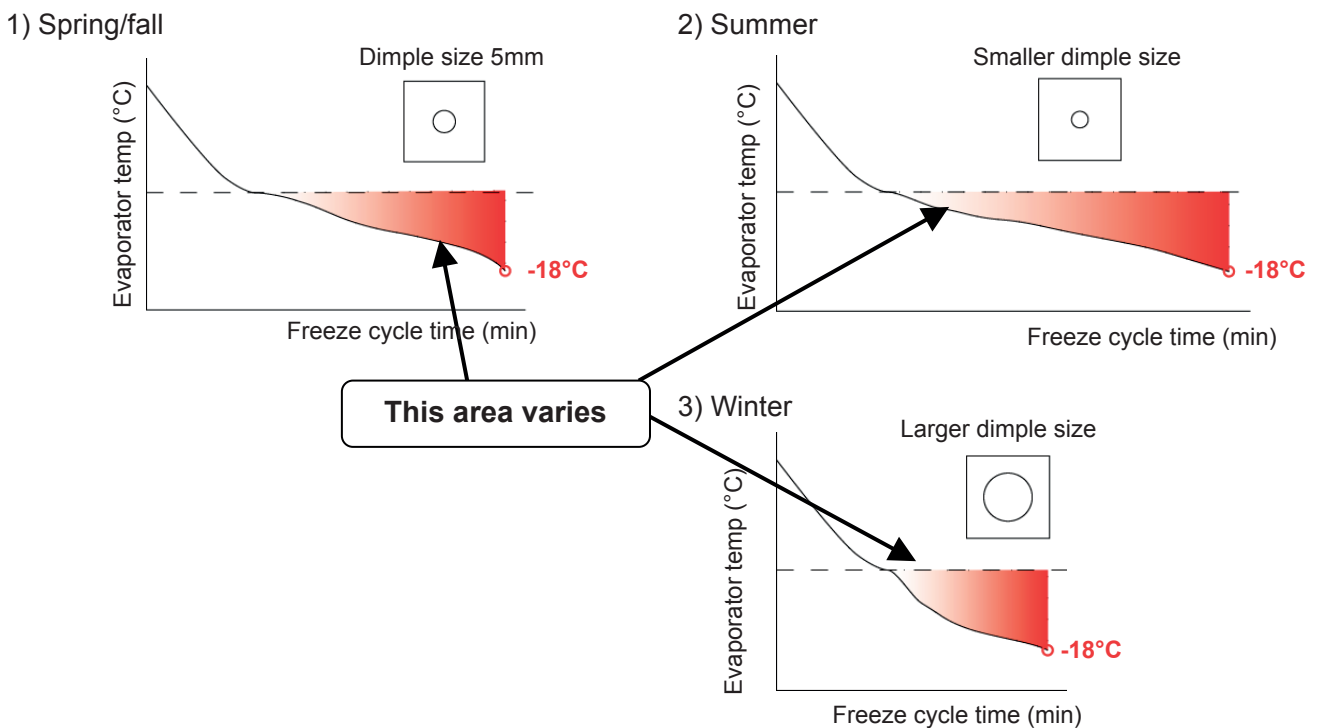

This area corresponds to the energy on ice. Making these different areas into one can equalize the dimple size.

To calculate the energy required for ice production, the actual ice production area under 0°C in the evaporator temperature curve is approximated into a triangle.

This area can be calculated by  
 $\text{Time} \times \text{temperature} \div 2$

Therefore,

**Energy required for ice production = time x temperature ÷ 2**

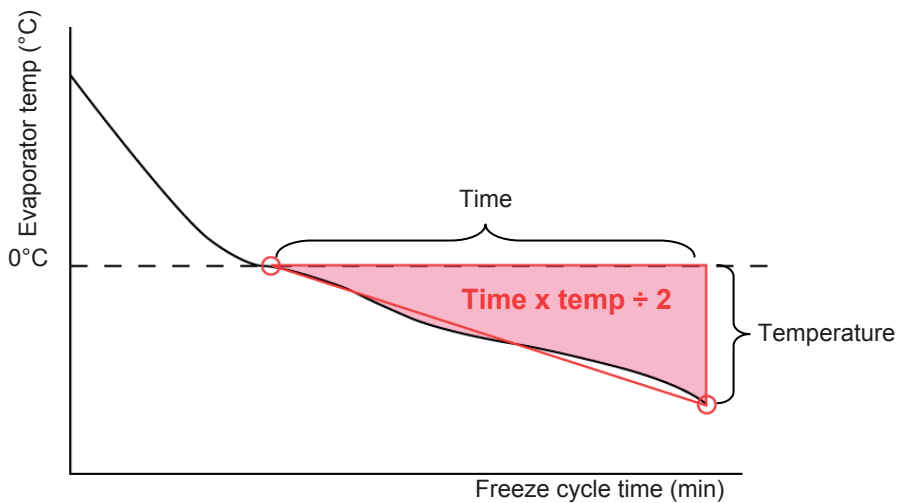

Providing the calculated energy to icemaking water can produce ice with fixed dimple size not affected by ambient conditions.

Actually, after the evaporator temperature becomes 0°C, the icemaker adds thermistor sensed temperature every second and continues ice production until the energy value calculated above (target freeze completion value) is reached.

To have stable ice production, it is necessary to calculate icemaking energy internally with the microprocessor. This energy calculation requires not just temperature but also time as shown in the above graph.

For this reason, both temperature and time are used to determine freeze completion.

## **[g] WATER SUPPLY CONTROL**

- 1) When the water pan closes and the hall IC turns on, the water valve opens to supply icemaking water for a specific time. The icemaking water supply time varies between startup, reset, and the end of bin control cycle.
  - \* The icemaking water supply time and additional water supply time are adjustable in the maintenance mode (see “3. [b] MAINTENANCE MODE”).
- 2) After the water pan starts to open, the water valve opens in 20 seconds to supply defrosting water (water pan cleaning water) for a specific time. The defrosting water supply time varies between the water temperatures above and below 13°C. If the water temperature is below 13°C, the water valve opens for 10 seconds after the water pan starts to close.
  - \* The defrosting water supply time is adjustable in the maintenance mode (see “3. [b] MAINTENANCE MODE”).
- 3) The water temperature is determined by a predetermined offset value plus the cube control thermistor temperature after icemaking water is supplied as mentioned in 1) and the pump motor runs for 30 seconds.
  - \* The water temperature offset value is adjustable in the maintenance mode (see “3. [b] MAINTENANCE MODE”).

## **[h] AMBIENT TEMPERATURE CORRECTION**

- 1) At low ambient temperatures, the dimple diameter of ice cubes is increased by a predetermined rate between the ambient temperature and target integrated freeze completion value to prevent reduction in the evaporator temperature leading to excessive ice production.
  - \* The rate between the ambient temperature and integrated value is adjustable in the maintenance mode (see “3. [b] MAINTENANCE MODE”).

## **[i] DIMPLE DIAMETER SETTING**

- 1) When the up or down switch is pressed, the current set point temperature (maintenance mode No. 2) is displayed (see “3. [b] MAINTENANCE MODE”).
- 2) When the up or down switch is pressed again, the set point temperature goes up or down in 0.5°C increments.
- 3) When the switches are not pressed for 30 seconds, the set point temperature is determined with “on” in the display.

## **[j] BIN CONTROL CYCLE**

- 1) When the bin control switch stays on for more than 10 seconds, the bin control cycle starts and the icemaker stops. After the bin control switch stays off for more than 80 seconds, the bin control cycle ends and the icemaker restarts. (The hot gas valve opens 30 seconds before the icemaker restarts.)
- 2) After the bin control cycle ends (or when the power supply is turned on), the water pan starts to open (if the icemaker stopped while the water pan was closing).
- 3) If the bin control switch turns on while the water pan is opening after the power supply is turned on (or after the reset switch is pressed), the bin control cycle does not start.

When the water pan opens and the hall IC turns on, the bin control cycle starts after 10 seconds and the icemaker stops.

## **[k] RESET SWITCH**

- 1) When the reset switch is pressed and released after the power supply is turned on, the soft start is reset within 3 seconds and the water pan starts to open in the initial cycle.
- 2) When the reset switch is pressed and released during operation (water pan opening or closing, defrost or freeze cycle), the icemaker returns to the initial cycle within 3 seconds and the water pan starts to open.
  - \* The above control is available because the water pan position is detected by the hall IC not by a change switch.
- 3) When the reset switch is pressed and released while the icemaker is off in the bin control cycle, the icemaker returns to the initial cycle within 3 seconds, the bin control cycle ends and the water pan starts to open.
- 4) When the reset switch is pressed and released while the icemaker is off with an error, the icemaker returns to the initial cycle within 3 seconds, the error is reset and the water pan starts to open.
  - \* When the icemaker returns to the initial cycle by the reset switch operation, the water temperature is assumed to be 0°C (below 13°C), the freeze back up timer is extended, the icemaking water supply time including additional water supply with the water pan closed doubles and the number of freeze cycles becomes 0.

## **[l] 7-SEGMENT LED**

- 1) When the power supply is turned on, the display shows “on” and the automatic icemaking process starts.
- 2) When the up or down switch is pressed, the display shows the current setting. When the switch is pressed again, the setting becomes adjustable. When the switches are not pressed for 30 seconds, the adjusted setting is determined with “on” in the display.
- 3) When an error occurs, the display flashes the applicable error code.
- 4) In the maintenance mode, the display shows various settings.
- 5) In the display mode, the display shows various values and the error history.

6) In the water circuit flush mode, the segments of the ones digit light up in rotation.

\* See "4. 7-SEGMENT DISPLAY" for further details.

### 3. MODE SETTING

#### [a] WATER CIRCUIT FLUSH MODE

1) When the down switch is pressed for 3 seconds during operation, the water circuit flush mode starts. The ones digit in the LED display lights up as follows.

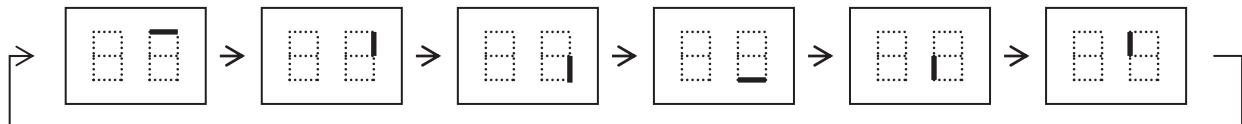

2) There is no 30-second standby time after the power supply is turned on. While the compressor stays off, the actuator motor starts to open the water pan. After the water pan closes, the water valve opens to supply water. Then, the pump motor starts.

3) When the reset switch is pressed during the flush process, the water pan opens to drain the water pan and water tank. Then, the water pan closes again, the water valve opens to supply water, and the pump motor starts.

4) Repeat the above step 3) as required.

\* Manually press the reset switch to open the water pan to drain water. If the icemaker keeps running in the flush mode with the water pan closed, the freeze backup timer operates and the display shows "E1".

\* If the cube control thermistor senses a temperature below the defrost completion temperature, the water pan keeps open, the defrost backup timer operates and the display shows "E2".

To reset, press the down switch for 3 seconds.

Note:

1. The freeze backup timer and defrost backup timer are available in the water circuit flush mode. As the compressor is off in the flush mode, these timers operate to stop the icemaker in case the freeze or defrost cycle does not complete.

2. As the compressor is off in the flush mode, be sure to drop all ice cubes in the defrost cycle before starting the flush mode. If any ice cube is left on the evaporator, the defrost backup timer operates to stop the icemaker.

3. After the flush mode is reset, the icemaker resumes operation from the defrost cycle.

\* If the up switch is pressed while the water pan is closing in the flush mode, the actuator motor stops and icemaking water is supplied for a specific time. Then, the pump motor starts to spray water. This allows for checking whether the spray holes are clogged or not.

## **[b] MAINTENANCE MODE**

When the reset switch is pressed for more than 3 seconds, the maintenance mode starts to allow various set values to be checked or adjusted.

- 1) Press the reset switch for more than 3 seconds while the unit is running. The display shows "1".
- 2) Press the up switch to increase the number and the down switch to decrease the number.
- 3) Press the reset switch to select the desired number. The current set value flashes in the display.
- 4) Press the up switch to increase the set value and the down switch to decrease the set value.
- 5) Press the reset switch to select the desired value. The display shows the number again.

To reset, leave the switches untouched for 30 seconds.



## Maintenance Mode List

|                                | No | Item  | Range   | Step |
|--------------------------------|----|---|---|------|
| Basic                          | 1  | Defrost completion temp                                     | 2 to 20°C   | 1    |
|                                | 2  | Integrated constant 1 (temp)                                | -5 to -40°C   | 0.5  |
|                                | 3  | Integrated constant 2 (time)                                | 5 to 90 min   | 1    |
|                                | 4  | Ambient temp correction operating temp for integrated value | 10 to 50°C  | 1    |
|                                | 5  | Ambient temp correction rate for integrated value           | 10 to 100% (00 = 100)   | 1    |
|                                | 6  | Freeze backup timer   | 45 to 90 min  | 5    |
| Water supply                   | 10 | Defrosting water supply time, water temp less than 13°C     | 1 to 99 sec, 99 = continuous  | 1    |
|                                | 11 | Defrosting water supply time, water temp 13°C or more       | 1 to 99 sec   | 1    |
|                                | 12 | Icemaking water supply time, normal                         | 0 to 90 sec   | 1    |
|                                | 13 | Water temp measurement correction value                     | +0 to +20K  | 1    |
|                                | 14 | Full / partial drain flush selection                        | 0: full / 1: partial  | 1    |
|                                | 15 | Additional icemaking water supply time                      | 0 to 90 sec   | 1    |
|                                | 17 | Defrosting water control                                    | 0: normal control<br>1: segmented control                               | 1    |
|                                | 18 | Defrost completion temp correction                          | +0 to +20K  | 1    |
| Others                         | 21 | Double stack bin control                                    | 0: No / 1: Yes  | 1    |
|                                | 22 | Refrigeration unit operation in bin control cycle           | 0: No / 1: Yes  | 1    |
| Model                          | 30 | Type  | 0: water-cooled (large)<br>1: small<br>2: medium / large<br>3: separate | 1    |
| Defrost cycle low temp control | 34 | Operating temp  | 40 to 70°C  | 1    |
| Water regulator                | 36 | Water regulator error detecting temp                        | 0 to 50°C, 0: cancel  | 1    |
| Compressor                     | 37 | Compressor output selection                                 | 0: X8 (DC relay) on<br>1: X1 (AC relay) on                              | 1    |
| Slush ice                      | 50 | Pump off time   | 0 to 90 sec, 0: no control  | 1    |
|                                | 51 | Water supply time   | 0 to 5 sec  | 1    |
| Hard water                     | 60 | Operating condition   | 10 to 100% (00 = 100)   | 1    |
|                                | 61 | Water supply time   | 0 to 90 sec   | 1    |
| Ice left in water pan          | 70 | Operating temp  | 10 to 60°C  | 1    |
|                                | 71 | Hot gas valve on time (*)                                   | 0 to 20 sec   | 1    |
|                                | 72 | Hot gas valve off time                                      | 0 to 60 sec   | 1    |
| Ice bridge                     | 73 | Hot gas valve off time                                      | 0 to 30 sec   | 1    |
| Low temp in defrost cycle      | 74 | Operating temp  | 0 to 40°C   | 1    |
| High Pressure                  | 80 | Sensed temp   | 55 to 70°C  | 1    |

(\*) For the controller boards of P01873-01 (Ver. 1.9A or later) and P01873-02 (Ver. 1.4A or later), No. 71 setting range is 0 to 10 sec.

## Maintenance Mode Descriptions

|              | No | Item  | Description   |
|--------------|----|---|---|
| Basic        | 1  | Defrost completion temp                                     | Temperature to complete defrost cycle (detected by cube control thermistor).  |
|              | 2  | Integrated constant 1 (temp)                                | Target integrated value inside controller board is determined by constants 1 and 2. Temperature in freeze cycle is integrated, and freeze cycle continues until target integrated value is reached. Basically, the smaller constant 1 gets, the bigger integrated value and the smaller dimple diameter become. |
|              | 3  | Integrated constant 2 (time)                                | Target integrated value inside controller board is determined by constants 1 and 2. Time in freeze cycle is integrated, and freeze cycle continues until target integrated value is reached. Basically, the smaller constant 2 gets, the smaller integrated value and the bigger dimple diameter become.        |
|              | 4  | Ambient temp correction operating temp for integrated value | Upper temperature limit to trip control to ensure minimum dimple size in low temp conditions like at 1°C / wt 5°C.  |
|              | 5  | Ambient temp correction rate for integrated value           | Percentage of integrated value in low temp conditions against target integrated value to ensure minimum dimple size in low temp conditions like at 1°C / wt 5°C based on integrated value inside controller board determined by constants 1 and 2.  |
|              | 6  | Freeze backup timer   | Timer setting to forcibly complete freeze cycle if cube control thermistor cannot sense freeze completion temp.   |
| Water supply | 10 | Defrosting water supply time, water temp less than 13°C     | Time to supply defrosting water to melt ice on water pan at water supply temp less than 13°C. Adjustable between 1 and 99 sec. When set to "99", defrosting water keeps running until cube control thermistor senses defrost completion temp.   |
|              | 11 | Defrosting water supply time, water temp 13°C or more       | Time to supply defrosting water to melt ice on water pan at water supply temp of 13°C or more. Adjustable between 1 and 99 sec. When set to "99", defrosting water keeps running until cube control thermistor senses defrost completion temp.  |
|              | 12 | Icemaking water supply time, normal                         | Time to supply icemaking water depending on partial or full drain flush.  |
|              | 13 | Water temp measurement correction value                     | Setting to correct difference between water temp measured by cube control thermistor and actual water supply temp.  |
|              | 14 | Full / partial drain flush selection                        | Selection between full and partial drain flush of icemaking water tank in case of cloudy ice production even after hard water control. Icemaking water supply time and water tank overflow pipe direction need to be changed.   |

|                                | No | Item  | Description  |
|--------------------------------|----|---|--|
| Water supply                   | 15 | Additional icemaking water supply time            | Time to supply additional icemaking water required after pump motor starts following normal icemaking water supply time (it is deactivated on this model).   |
|                                | 17 | Defrosting water control                          | Selection of defrosting water control. When set to "0", normal control as described for No. 11 above. When set to "1", control timing is segmented into two.   |
|                                | 18 | Defrost completion temp correction                | Set defrost completion temp correction value when defrosting water control setting is changed.   |
| Others                         | 21 | Double stack bin control                          | Selection of bin control in case of double stack application.  |
|                                | 22 | Refrigeration unit operation in bin control cycle | Selection of control to prevent ice in storage bin from melting in bin control cycle (by operating refrigeration unit).  |
| Model                          | 30 | Type  | Selection of fan motor type. When set to "0", unit operates as water-cooled model.   |
| Defrost cycle low temp control | 34 | Operating temp                                    | Set temp for continuous fan motor operation in defrost cycle to lower temp inside control box if ambient temp at the beginning of defrost cycle exceeds set point.   |
| Water regulator                | 36 | Water regulator error detecting temp              | Thermistor temp (water regulator outlet) in case of water regulator error and cooling water failure for water-cooled model.  |
| Compressor                     | 37 | Compressor output selection                       | Selection between AC supply and DC supply (normal setting = AC supply). Transformer voltage drop is too large to input both.   |
| Slush ice                      | 50 | Pump off time                                     | Pump off time for slush ice control to stop pump after 2 min (controller board P01873-01) or 30 sec (P01873-02) at evaporator temp of 3 to 4°C, quickly refrigerate evaporator before icemaking water supercools, and form ice core. When set to "0", there is no slush ice control.   |
|                                | 51 | Water supply time                                 | Time to supply water while pump is off for slush ice control. If slush ice is too much and cannot be prevented solely by pump off in No. 50, water is supplied while pump is off to slightly raise tank water temp.  |
| Hard water                     | 60 | Operating condition                               | Condition to operate cloudy ice control in hard water application indicated in percentage against target integrated value. After icemaking water supply starts, ice begins to form and freeze cycle integrated value reaches a certain level. Then, additional water is supplied to dilute concentrated icemaking water in water tank. |
|                                | 61 | Water supply time                                 | Time to supply water for hard water control.   |
| Ice left in water pan          | 70 | Operating temp                                    | Upper limit of operating temp to control ice left in water pan at the end of freeze cycle. Decrease amount of defrosting water by reducing ice left in opening water pan after freeze cycle.   |
|                                | 71 | Hot gas valve on time                             | Hot gas valve opening time to control ice left in water pan.   |
|                                | 72 | Hot gas valve off time                            | Hot gas valve closing time to control ice left in water pan.   |

|                           | No | Item                   | Description   |
|---------------------------|----|------------------------|---|
| Ice bridge                | 73 | Hot gas valve off time | Time to keep hot gas valve closed after 20 sec in defrost cycle. Prevent ice bridge in bin by delaying ice dropping time (it is deactivated on this model). |
| Low temp in defrost cycle | 74 | Operating temp         | Upper temperature limit at the beginning of defrost cycle.  |
| High Pressure             | 80 | Sensed temp            | Temperature sensed by condenser thermistor  |

Note: To prevent the actuator motor defects,

\*1. **Do not set the defrost completion temperature low.**

The **defrost completion temperature** is used to ensure the **required standby time until the water pan starts to close** after ice is released from the evaporator.

When the evaporator temperature reaches 0°C, ice is gradually released (drops into the bin) from the evaporator and the water pan starts to close as the target temperature is reached.

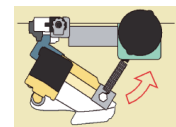
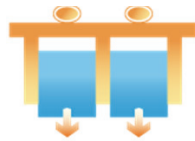

Ice is released --> **Standby time is ensured** --> Start to close

The target temperature is factory adjusted so that it will take **about 20 seconds** for the water pan to start closing after release of ice **when the ambient temperature is around 30°C.**

\* The evaporator temperature rises depending on the ambient temperature. The water pan starts to close earlier when the ambient temperature is higher and the water pan starts to close later when the ambient temperature is lower.

**i.e. Approx. 20 sec at 30°C < 30 sec at 20°C < 60 sec at 10°C**

**If defrost completion temperature is low...**

**If the setting change is made when the ambient temperature is low,** the evaporator temperature rises from 0°C to the target temperature before the end of the defrost cycle (ice is released from the evaporator) when the ambient temperature becomes higher. In this case, the water pan starts to close in the middle of the defrost cycle and ice will be stuck between the evaporator and water plate, which will cause an excessive load on the actuator motor gear.

**If ice cubes are released separately from the evaporator,** the water pan starts to close when the thermistor senses the target temperature, even if some ice cubes are left on the evaporator. In this case, the freeze cycle begins (resumes) with ice cubes left on the evaporator, resulting in making abnormal shape of ice which can easily be stuck and cause an excessive load on the actuator motor gear.

**\*2. Do not make dimple diameter small.**

The dimple in ice is necessary and important to repeat the freeze and defrost cycles normally. The freeze completion temperature and time are factory adjusted to make **the dimple diameter more than 5 mm on average.**

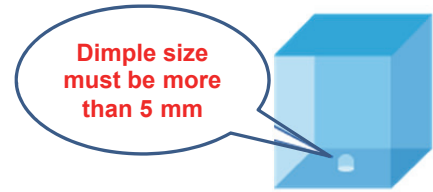

**If dimple in ice is small...**

**Some spray holes and return holes in the water plate freeze.** The load on the actuator motor gear rapidly increases when ice is forced to be released (by cam rotation) during the defrost cycle.

**If ice is forced to be released when the spray holes and return holes on the water plate are frozen,** the linked parts of ice in the evaporator are torn off and remain frozen on the surface of the water plate. This linked ice is not completely melted by the cleaning water (water supply) for flushing the water plate surface and remains widely on the water plate when ice is released from the evaporator.

Furthermore, a smaller amount of linked parts during the defrost cycle tends to make ice stuck between the evaporator and water plate. That is because ice cubes are released separately (each ice cube is lightweight) and easily get stuck on ice attached to the water plate surface, which will cause an excessive load on the actuator motor gear.

\*There is no problem making the dimple diameter larger (10 to 15 mm) to increase the ice making capacity or shorten the freeze cycle time.

## Maintenance Mode Settings

|                                | No | Item  | DIM-30DE-2 |                           |
|--------------------------------|----|---|------------|---------------------------|
|                                |    |   | Tin plated | Electroless nickel plated |
| Basic                          | 1  | Defrost completion temp                                     | 5          | 5                         |
|                                | 2  | Integrated constant 1 (temp)                                | -16.5      | -17                       |
|                                | 3  | Integrated constant 2 (time)                                | 14         | 14                        |
|                                | 4  | Ambient temp correction operating temp for integrated value | 38         | 38                        |
|                                | 5  | Ambient temp correction rate for integrated value           | 75         | 75                        |
|                                | 6  | Freeze backup timer   | 45         | 45                        |
| Water supply                   | 10 | Defrosting water supply time, water temp less than 13°C     | 15         | 15                        |
|                                | 11 | Defrosting water supply time, water temp 13°C or more       | 6          | 6                         |
|                                | 12 | Icemaking water supply time                                 | 20         | 20                        |
|                                | 13 | Water temp measurement correction value                     | 7          | 10                        |
|                                | 14 | Full / partial drain flush selection                        | 0          | 0                         |
|                                | 15 | Additional icemaking water supply time                      | 0          | 0                         |
|                                | 17 | Defrosting water control                                    | 0          | 0                         |
| Other                          | 21 | Defrost completion temp correction                          | 0          | 0                         |
|                                | 22 | Double stack bin control                                    | 1          | 1                         |
| Model                          | 30 | Refrigeration unit operation in bin control cycle           | 0          | 0                         |
| Defrost cycle low temp control | 34 | Type  | 1          | 1                         |
| Water regulator                | 36 | Operating temp  | 45         | 45                        |
| Compressor                     | 37 | Water regulator error detecting temp                        | 0          | 0                         |
| Slush ice                      | 50 | Compressor output selection                                 | 0          | 0                         |
|                                | 51 | Pump off time   | 30         | 90                        |
| Hard water                     | 60 | Water supply time   | 0          | 0                         |
|                                | 61 | Operating condition   | 10         | 10                        |
| Ice left in water pan          | 70 | Water supply time   | 0          | 0                         |
|                                | 71 | Operating temp  | 23         | 47                        |
|                                | 72 | Hot gas valve on time                                       | 10         | 10                        |
| Ice bridge                     | 73 | Hot gas valve off time                                      | 20         | 20                        |
| Low temp in defrost cycle      | 74 | Hot gas valve off time                                      | 0          | 0                         |
|                                |    | Operating temp  | 15         | 15                        |

### [c] DISPLAY MODE (LOG CLEARING)

When the up switch is pressed for more than 3 seconds, the display mode starts to allow various items and logs to be checked, displayed or cleared.

- 1) Press the up switch for more than 3 seconds while the unit is running. The display shows "n1".
- 2) Press the up switch to increase the number and the down switch to decrease the number.
- 3) Press the reset switch to select the desired number. The current value appears in the display.
- 4) Press the reset switch while the value is displayed. The display shows the number again.

To reset, leave the switches untouched for 30 seconds.

To clear, press the up and down switches together for 5 seconds while the value is displayed.

#### Display Mode List

| No | Item                                 | Description  | Clear |
|----|--------------------------------------|--|-------|
| n1 | Freeze cycle time count up (min)     | 0 to 99 min  | No    |
| n2 | Freeze cycle completion rate (%)     | 0 to 100% (00 = 100%)  | No    |
| n3 | Current cube control thermistor temp | Rounded to the nearest whole number  | No    |
| n4 | Current ambient thermistor temp      | Rounded to the nearest whole number  | No    |
| n5 | Water temp (presumed)                | "H" for 13°C or more<br>"L" for less than 13°C   | No    |
| n6 | Current condenser thermistor temp    | Rounded to the nearest whole number  | No    |
| h1 | Last freeze cycle time (min)         | Same as current freeze cycle time. Freeze cycle is not considered complete if interrupted by bin control switch or reset switch.                                     | Yes   |
| h2 | Number of freeze cycles              | Number of cycles completed. 10 is added every 10 cycles. Freeze cycle is not considered complete or counted in if interrupted by bin control switch or reset switch. | Yes   |
| h3 | Total number of freeze cycles        | < Display ><br>e.g. 655350 cycles<br>(start) (end)<br>65→off→53→off→50→off→ - -<br>↑   | No    |

| No | Item               | Description  | Clear  |
|----|--------------------|--|--------|
| h4 | Error log          | Display up to 5 errors from latest to oldest for 1 sec ON, 0.5 sec OFF, "- -" at the end, then back to latest error. In case of less than 5 errors, display oldest error, "- -", then back to latest one.<br>< Display ><br>e.g. E5 (latest), E4, E3, E2, E1 (oldest)<br>(latest) (oldest)<br>E5→off→E4→off→E3→off→E2→off→E1→off→ - -<br>↑ | Yes    |
| h5 | Software version   | For Ver. 1.0A, display "01."→"0A"→"01." alternately for 1 sec ON, 0.5 sec OFF.   | No     |
| h6 | Default model code | Display set model codes from "00" to "FF" (hexadecimal, 256 patterns)  | No (*) |

\* To clear the model code, press the up and down switches together for 15 seconds (for controller board replacement and setting error correction only).

### [d] MODEL CODE SETTING MODE

Note: Use this mode only when the controller board is replaced or the model code setting needs to be corrected.

- 1) When the up switch is pressed for more than 3 seconds, the display mode starts and the display shows "n1".
- 2) Press the up or down switch to have "h6" in the display.
- 3) Press the reset switch. The current memorised model code appears in the display.
- 4) Press the up and down switches together for 15 seconds. The display shows "00". When the controller board P01873-02 is used, the hyphen on the top left lights up.
- 5) Press the up switch to increase the first digit in the 7-segment display, and the down switch to increase the second digit. The digit changes in the following order: 0, 1, 2, 3, 4, 5, 6, 7, 8, 9, A, B, C, D, E, F, H, J, L, N. Set the proper model code according to the model code list below. When a preset model code is displayed, the dot on the bottom right lights up.
- 6) When the chosen preset model code is displayed, press the reset switch to store the board memory (the display shows "on" and the machine will then always start up with this memorized program as default).

\* To check the current memorised model code, view in the display mode (follow steps 1) to 3) above).



Controller Board P01873-01

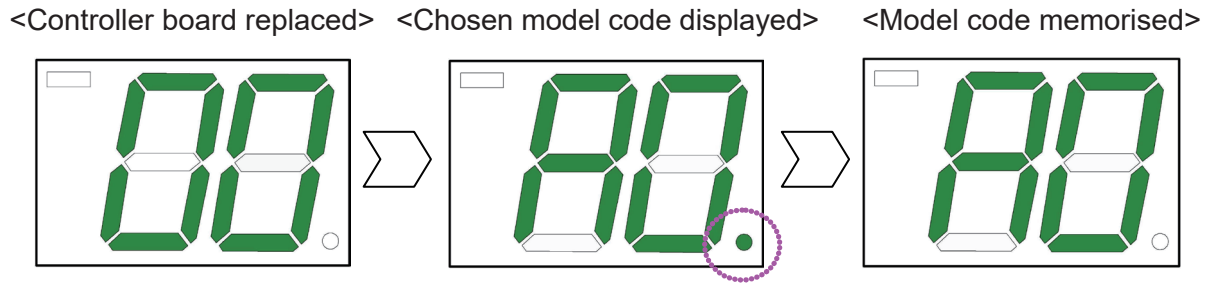

Controller Board P01873-02

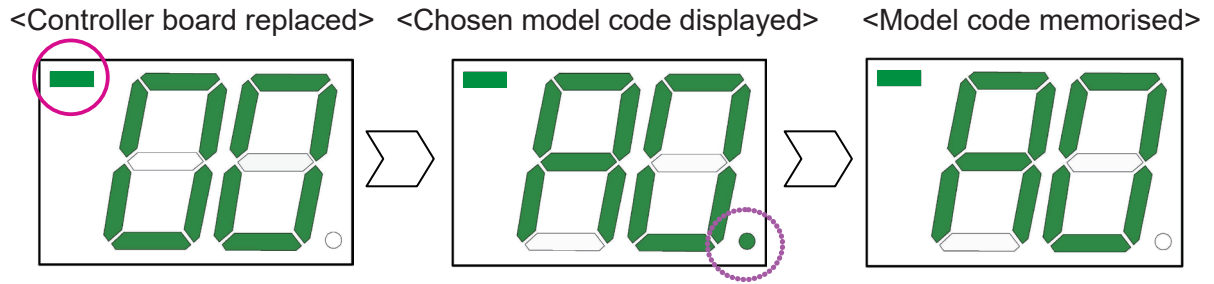

Model Code List

| 1st Digit | 2nd Digit | Model      |
|-----------|-----------|------------|
| 1         | 0         |            |
|           | 1         |            |
|           | 2         |            |
|           | 3         |            |
|           | 4         |            |
|           | 5         |            |
|           | 6         |            |
|           | 7         |            |
|           | 8         |            |
|           | 9         | DIM-30DE-2 |
|           | A         |            |
|           | B         |            |
|           | C         |            |
|           | D         |            |
|           | E         |            |
| F         |           |            |
| H         |           |            |
| J         |           |            |
| L         |           |            |
| N         |           |            |



## 4. 7-SEGMENT DISPLAY

### [a] NORMAL MODE







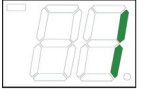



| Item  | Display   |
|---|---|
| Power on<br>Defrost cycle<br>Freeze cycle<br>Bin full |   |
| Freeze temp setting                                   | Display range from -5.0 to -40.0<br>  |
| Error code  | Flash<br><br>E1: Abnormal freeze cycle<br>E2: Abnormal defrost cycle<br>EE: Other<br>(See "5. ERROR CODES") |
| Water circuit flush                                   |   |

### [b] MAINTENANCE MODE

| No. | Item  | Display (example)   |
|-----|---|---|
| 1   | Defrost completion temp                                     | <br>16°C  |
| 2   | Integrated constant 1 (temp)                                | -18°C      -18.5°C<br><br><br>Dot appears for value with ".5" as in -18.5°C |
| 3   | Integrated constant 2 (time)                                | <br>21 min  |
| 4   | Ambient temp correction operating temp for integrated value | Same as No. 1   |

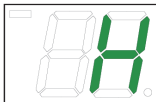
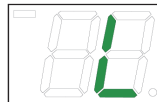
| No. | Item  | Display (example)   |
|-----|---|---|
| 5   | Ambient temp correction rate for integrated value       |  90%  100% (last 2 digits only) |
| 6   | Freeze backup timer                                     | Same as No. 3   |
| 10  | Defrosting water supply time, water temp less than 13°C | Same as No. 3 (unit: sec)   |
| 11  | Defrosting water supply time, water temp 13°C or more   | Same as No. 3 (unit: sec)   |
| 12  | Icemaking water supply time, normal                     | Same as No. 3 (unit: sec)   |
| 13  | Water temp measurement correction value                 | Same as No. 1   |
| 14  | Full / partial drain flush selection                    | Same as Nos. 21 and 22  |
| 15  | Additional icemaking water supply time                  | Same as No. 3 (unit: sec)   |
| 17  | Defrosting water control                                | Same as Nos. 21 and 22  |
| 18  | Defrost completion temp correction                      | Same as No. 1   |
| 21  | Double stack bin control                                | 0  1                          |
| 22  | Refrigeration unit operation in bin control cycle       |   |
| 30  | Model type  | Same as Nos. 21 and 22<br>(Setting range from 0 to 3)   |
| 34  | Defrost cycle low temp control, operating temp          | Same as No. 1   |
| 36  | Water regulator error detecting temp                    | Same as No. 1   |
| 37  | Compressor output selection                             | Same as Nos. 21 and 22  |
| 50  | Slush ice, pump off time                                | Same as No. 3 (unit: sec)   |
| 51  | Slush ice, water supply time                            | Same as No. 3 (unit: sec)   |
| 60  | Hard water, operating condition                         | Same as No. 5   |
| 61  | Hard water, water supply time                           | Same as No. 3 (unit: sec)   |
| 70  | Ice left in water pan, operating temp                   | Same as No. 1   |
| 71  | Ice left in water pan, hot gas valve on time            | Same as No. 3 (unit: sec)   |
| 72  | Ice left in water pan, hot gas valve off time           | Same as No. 3 (unit: sec)   |
| 73  | Ice bridge, hot gas valve off time                      | Same as No. 3 (unit: sec)   |
| 74  | Low temp in defrost cycle, operating temp               | Same as No. 1   |

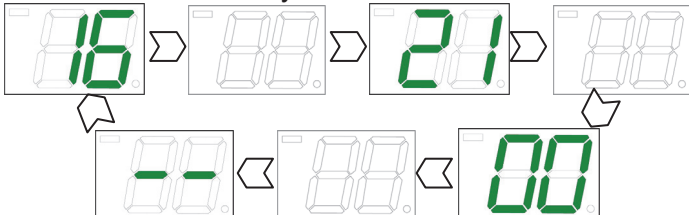
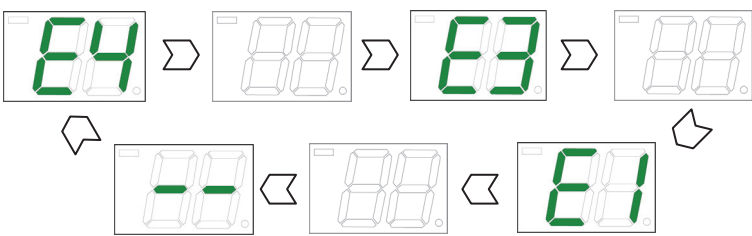
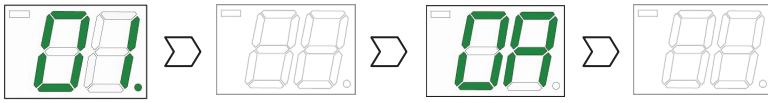
## [c] DISPLAY MODE

| No | Item                                 | Display (example)  |   |
|----|--------------------------------------|--|---|
| -  | n*, h*                               |     |  |
| n1 | Freeze cycle time count up (min)     | 21 min or 21%  | 100% (last 2 digits only)   |
| n2 | Freeze cycle completion rate (%)     |     |  |
| n3 | Current cube control thermistor temp | -19°C  | 24°C  |
| n4 | Current ambient thermistor temp      |     |  |
| n5 | Water temp (presumed)                | Water temp 13°C or more  | Water temp less than 13°C   |
|    |                                      |     |  |
| n6 | Current condenser thermistor temp    | Same as n3 and n4  |   |
| h1 | Last freeze cycle time (min)         |     | 21 min  |
| h2 | Number of freeze cycles              | If counted number of cycles is 162100  |   |
|    |                                      |   |   |
| h3 | Total number of freeze cycles        |  |   |
| h4 | Error log                            | If 3 errors from latest to oldest are E4, E3, and E1                                 |   |
|    |                                      |  |   |
| h5 | Software version                     | Ver. 1.0A is displayed as follows alternately for 1 sec ON and 0.5 sec OFF           |   |
|    |                                      |  |   |
| h6 | Default model code                   | Set model codes from "00" to "FF" (hexadecimal, 256 patterns)                        |   |
|    |                                      |  |   |

## 5. ERROR CODES

### [a] ERROR CODES, CAUTION CODES

\* When the controller board detects an error, the display shows one of the following error, caution and alarm codes in the display mode. Operation depends on the type of error.

\* The error and caution codes other than E1 and E2 are indicated as “EE” or “EF” in the 7-segment display at the time of occurrence. The error log is indicated up to five errors from the latest entry.

| Error | Item                          | Description   | Operation | Reset                    |
|-------|-------------------------------|---|-----------|--------------------------|
| E1    | Freeze error                  | Freeze backup timer (45/60 minutes after water pan starts to close) counts up before freeze cycle completes, and evaporator temperature is 0°C or higher. | Shut down | Press reset switch       |
| E2    | Defrost error                 | Defrost backup timer (30 minutes after water pan starts to open) counts up before defrost cycle completes.  | Shut down | Press reset switch       |
| E3    | Water pan opening error       | Water pan has not fully opened within 60 seconds, and 3 minutes have passed even with opening failure control.  | Halt      | Press reset switch       |
|       |                               | Unit resumes operation after 60 minutes and repeats the above error.  | Shut down |                          |
| E4    | Water pan closing error       | Water pan has not fully closed within 50 seconds, opened and started to close again, but failed to close fully within 50 seconds.                         | Halt      | Press reset switch       |
|       |                               | Unit resumes operation after 60 minutes and repeats the above error.  | Shut down |                          |
| E5    | High temperature error        | Evaporator temperature stays 60°C or higher for 5 seconds or more.  | Shut down | Press reset switch       |
| E9    | Condenser thermistor error    | Condenser thermistor circuit is open or shorted for 2 seconds.  | Shut down | Replace thermistor       |
| EA    | Data error                    | Model setting data memory IC is defective.  | Shut down | Replace controller board |
| EC    | Cube control thermistor error | Cube control thermistor circuit is open or shorted for 2 seconds.   | Shut down | Replace thermistor       |
| Ed    | Water regulator error         | Cooling water cannot stop by water regulator error, and thermistor senses set point or lower temperature.   | Continue  | Press reset switch       |

**[b] SERVICE DIAGNOSIS**

| Error                   | Check                   | Possible Cause              | Remedy  |
|-------------------------|-------------------------|-----------------------------|---|
| E1                      | Water valve             | Closing failure             | Clean or replace                                      |
|                         | Refrigeration circuit   | Gas leak                    | Repair  |
|                         |                         | Clogged capillary           | Replace heat exchanger                                |
|                         | Compressor              | Defective                   | Replace   |
|                         |                         | Starting failure            | Check supply voltage or replace electrical components |
|                         | Compressor relay        | Coil circuit open           | Replace   |
|                         | Condenser               | Clogged                     | Clean   |
|                         | Fan motor               | Locked                      | Replace   |
|                         |                         | Low RPM                     | Replace   |
|                         |                         | Broken fan                  | Replace fan   |
| Hot gas valve           | Closing failure         | Replace                     |   |
| Cube control thermistor | Disconnected            | Reconnect                   |   |
| E2                      | Hot gas valve           | Opening failure             | Replace   |
|                         | Controller board        | Defective                   | Replace   |
| E3                      | Actuator motor          | Defective                   | Replace   |
|                         | Controller board        | Relay contact failure       | Replace   |
|                         |                         | Defective                   | Replace   |
| E4                      | Actuator motor          | Defective                   | Replace   |
|                         | Controller board        | Relay contact failure       | Replace   |
|                         |                         | Defective                   | Replace   |
| E5                      | Hot gas valve           | Closing failure             | Replace   |
|                         | Controller board        | Relay contact failure       | Replace   |
| E9                      | Condenser thermistor    | Open or short circuit       | Replace   |
|                         | Controller board        | Connector disconnected      | Reconnect   |
| EA                      | Controller board        | Defective                   | Replace   |
| EC                      | Cube control thermistor | Open or short circuit       | Replace   |
|                         | Controller board        | Connector disconnected      | Reconnect   |
| Ed                      | Water regulator         | Clogged with foreign matter | Unclog  |
|                         |                         | Corroded spring             | Replace   |

## 6. TROUBLESHOOTING

### IMPORTANT

If receiving a service call, ask the user to turn off the power to the ice dispenser and turn it on again, while watching the ice dispenser. This will reset the controller, and in some cases normal operation will resume.

#### [a] INSTRUCTIONS FOR SERVICE ENGINEER

- 1) Check that the icemaker has been earthed properly. If not, the controller board will not work properly.
- 2) Do not change wiring and connections, or the controller board will not work properly.
- 3) Do not touch the electronic devices on the controller board or the back of the controller board.
- 4) Do not repair the electronic devices and parts on the controller board in the field except for the fuse (250V AC, 6.3A, 5mm DIA x 20mm).
- 5) To get static free, always touch the metal part of the icemaker before servicing.
- 6) Handle the controller board by the edges only.
- 7) Do not drop the controller board on the floor.

#### [b] CHECKING CONTROLLER BOARD

- 1) Before checking the controller board, check the cube control thermistor and bin control switch for proper operation. See "BEFORE CHECKING CONTROLLER BOARD" in the service manual for the applicable model.
- 2) If the above parts are operating properly, check each part according to "5. [b] SERVICE DIAGNOSIS".

## 7. REMOVAL AND REPLACEMENT

The replacement controller board is in common use for the entire IM\_N models (HE).

To replace:

- 1) Unplug the icemaker or disconnect the power source.
- 2) Remove the front panel and control box cover.
- 3) Disconnect all the connectors from the controller board. Remove the controller board from the control box.
- 4) Install the replacement controller board in the control box. Reconnect the connectors.
- 5) Replace the control box cover and front cover.
- 6) Plug in the icemaker or connect the power source. As the replacement controller board has not been set for the proper model code, the 7-segment display illuminates "00". When the controller board P01873-02 is used, the hyphen on the top left lights up.
  - \* The code "00" does not belong to any model.
- 7) Press the up switch to increase the first digit in the 7-segment display, and the down switch to increase the second digit. The digit changes in the following order: 0, 1, 2, 3, 4, 5, 6, 7, 8, 9, A, B, C, D, E, F, H, J, L, N. Set the proper model code according to the model code list provided with the replacement controller board (see 3. [d] MODEL CODE SETTING MODE). When a preset model code is displayed, the dot on the bottom right lights up.
- 8) When the chosen preset model code is displayed, press the reset switch to store the board memory (the display shows "on" and the machine will then always start up with this memorized program as default).
- 9) Replace the front panel.

### Controller Board P01873-01

<Controller board replaced>   <Chosen model code displayed>   <Model code memorised>

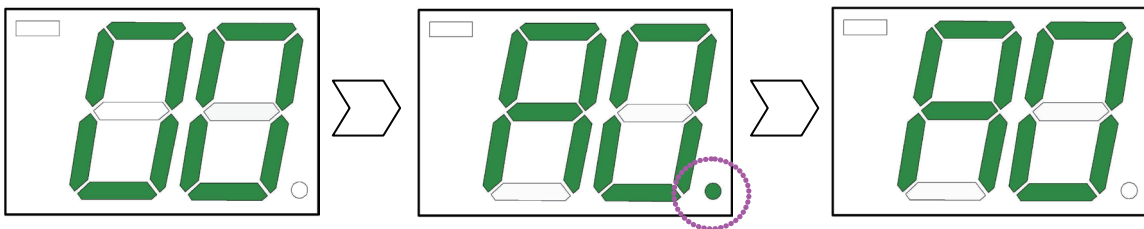

### Controller Board P01873-02

<Controller board replaced>   <Chosen model code displayed>   <Model code memorised>

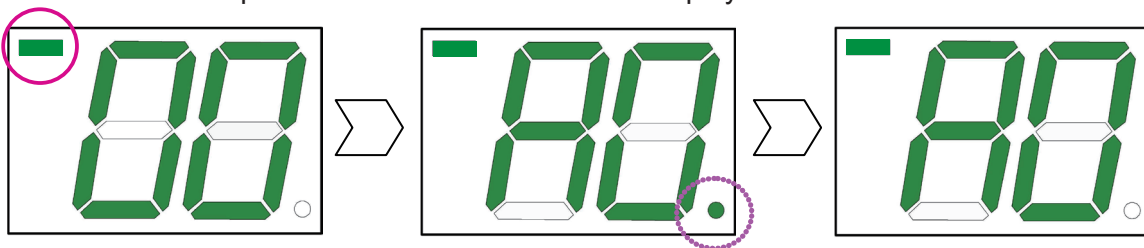



- \* To check the current memorised model code, view in the display mode (press and hold the up switch for 3 seconds – the display changes to “n1”, then press the up switch several times to find “h6”, then press the reset switch and the memorised code appears in the display).
- \* If for any reason the machine needs to be reset back to the factory settings, hold the up and down switches for 15 seconds whilst the code is displayed (in display mode). The machine will stop working and the display will reset to “00” (cleared memory). The controller board will then need to be reprogrammed (select and memorise the correct code for the machine) using steps 7) and 8) above.

Note:

1. Be sure to get static free before servicing the controller board.
2. Do not touch the controller board with wet or dirty hands.
3. Do not impact the controller board. If it drops on the floor, do not use it.
4. Do not hold the leads when disconnecting the connectors.
  - \* Locking connectors must be unlocked before being disconnected.
  - \* Reconnect the connectors properly.
5. Install the new controller board in its correct position.
6. Bind the wiring inside the control box the way it was.
  - \* Do not push the wiring on the controller board.
  - \* Do not bind the thermistor leads and high voltage wires together.

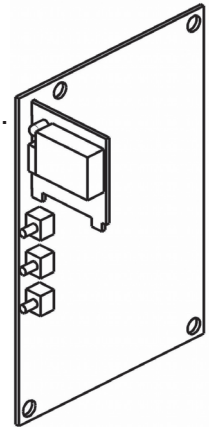

# 8. TIMING CHART

Ice production at normal temperature (RT 15°C, WT above 13°C)

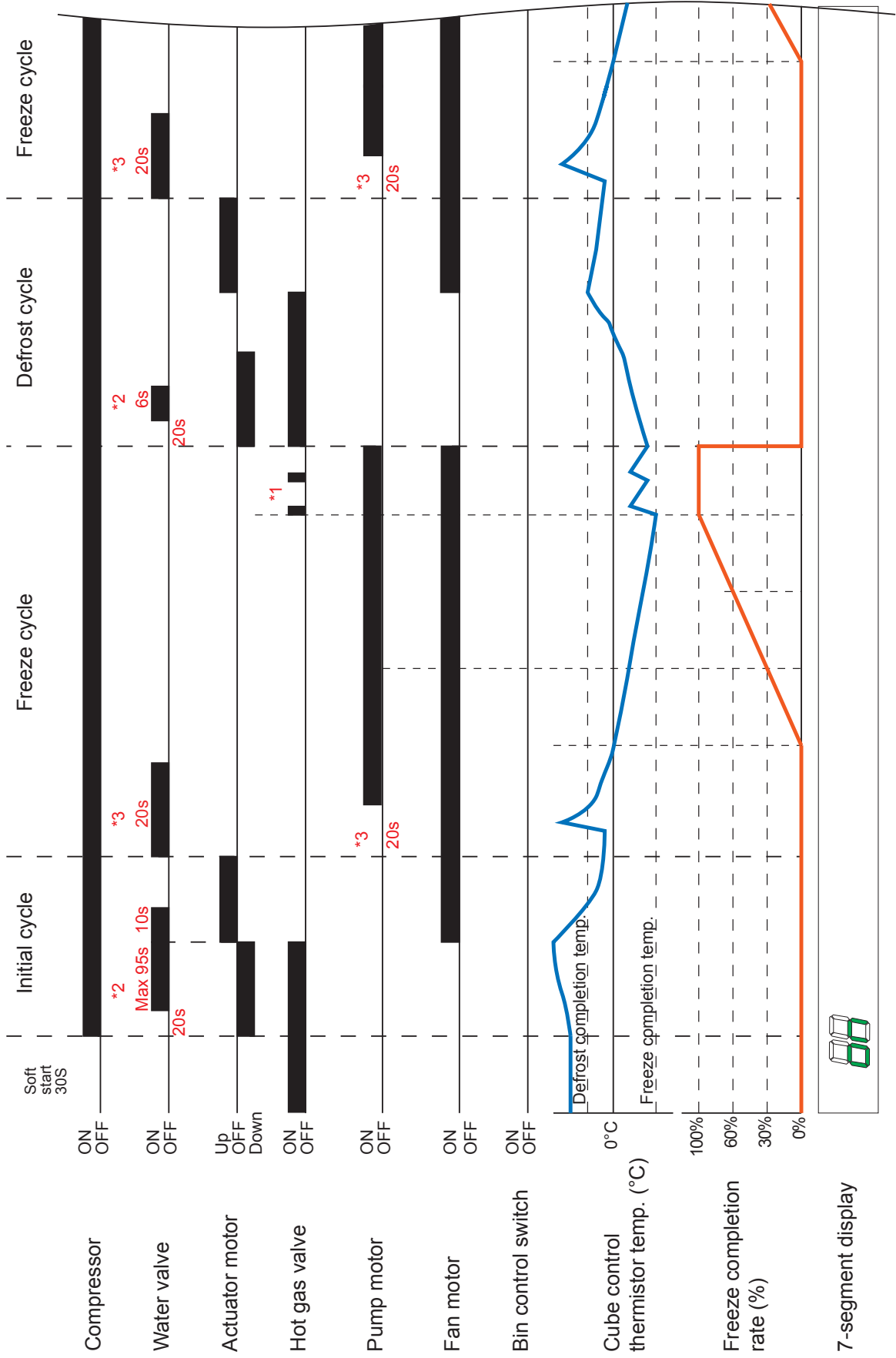

Ice storage at normal temperature (RT 15°C, WT above 13°C)

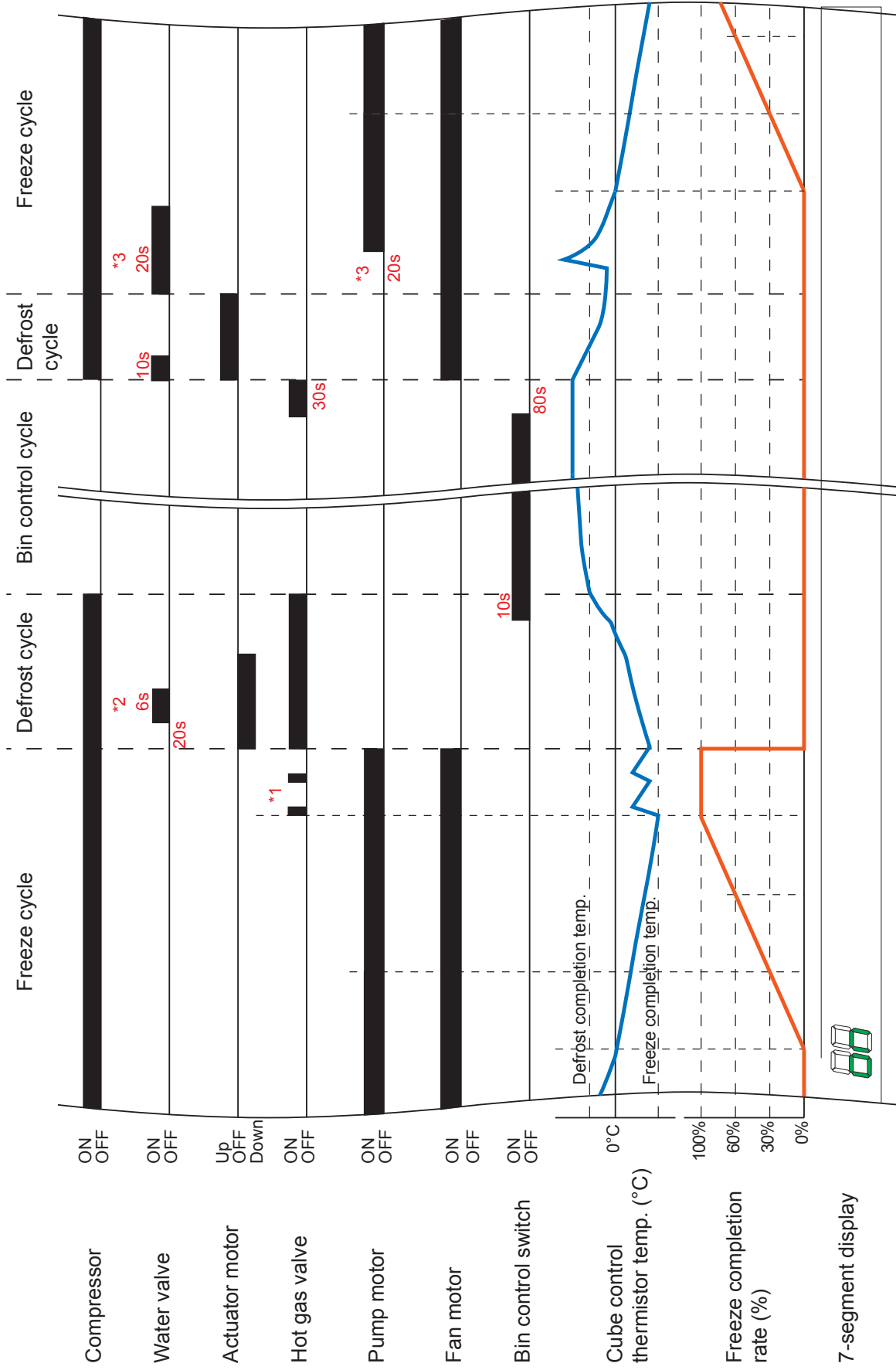

**Notes on timing charts (\*1, \*2, \*3)**

|   | Item                      | DIM-30DE-2   |
|---|---------------------------|--------------|
| *1 Water pan defrost control  | Ambient temp in control   | 23°C or less |
|   | Hot gas valve on/off time | 10/20s       |
| *2 Defrosting water supply time (water temp less than 13°C, or initial cycle) |                           | 15s          |
| *2 Defrosting water supply time (water temp 13°C or more)                     |                           | 6s           |
| *3 Icemaking water / additional water supply time                             |                           | 20s          |

- 1) When the power is turned on or the unit resumes operation after a bin control cycle, the water temperature is considered less than 13°C and the water valve opens for 15 seconds to supply defrosting water. If the water temperature is normal, the water pan opens and immediately starts to close again. In this case, defrosting water flows for 6 seconds.
- 2) The pump motor starts after the water pan closes and the icemaking water supply completes.

### III. OPERATING INSTRUCTIONS

#### 1. IN CASE OF DIRTY WATER

##### Auxiliary code: K0 or earlier

- 1) Remove the switch cover, and turn off the power switch.
- 2) Close the water supply tap.
- 3) Unlock the front panel (upper) by turning the keyhole counterclockwise with a flat blade screwdriver. Unscrew and lift off the front panel (upper). See Fig. 1.
- 4) Wait for 5 minutes, and turn on the power switch.
- 5) Forty seconds after the icemaking compartment starts operation, turn off the power switch immediately to drain the water tank. Note the open position of the water tank.
- 6) Refit the front panel (upper), and push down its top while turning the keyhole clockwise. See Fig. 2.

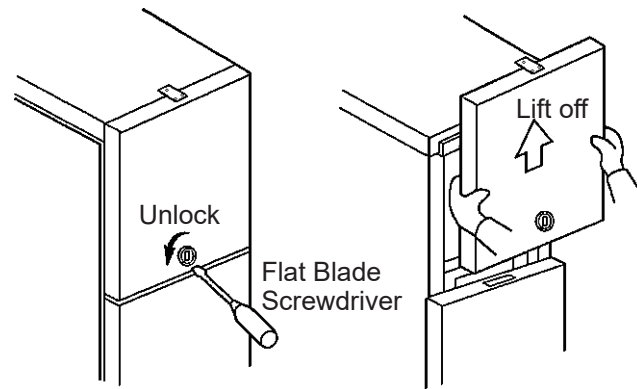

Fig. 1

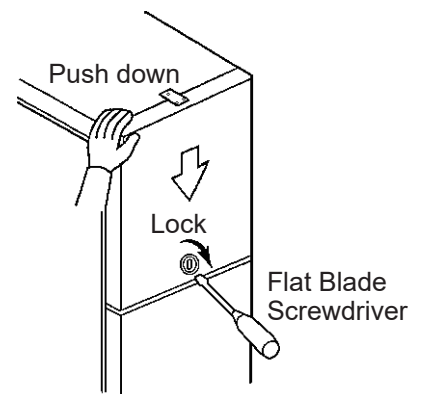

Fig. 2

- 7) When water supply is resumed, open the drain valve first. Then, gradually open the water supply tap to completely drain out dirty water.
- 8) Turn on the power switch to restart the ice dispenser.

##### Auxiliary code: K1 or later

- 1) Remove the switch cover, and turn off the power switch.
- 2) Close the water supply tap.
- 3) Unscrew and lift the front panel. See Fig. 3.
- 4) Wait for 5 minutes, and turn on the power switch.
- 5) Forty seconds after the icemaking compartment starts operation, turn off the power switch immediately to drain the water tank. Note the open position of the water tank.
- 6) Refit the front panel and screw it in place. See Fig. 3.

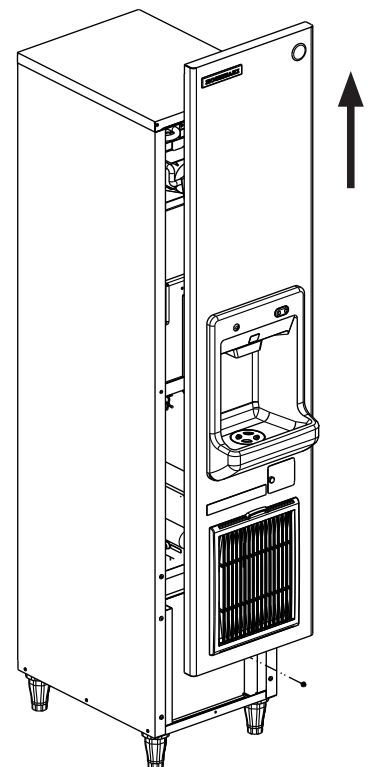

Fig. 3

- 7) When water supply is resumed, open the drain valve first. Then, gradually open the water supply tap to completely drain out dirty water.
- 8) Refit the switch cover. Turn on the power switch to restart the ice dispenser.

## **2. PREPARING THE ICE DISPENSER FOR LONG STORAGE**

### **Auxiliary code: K0 or earlier**

- 1) Press the push button to dispense all ice from the storage bin.
- 2) Follow the steps 1) to 5) in “1. IN CASE OF DIRTY WATER”.
- 3) Blow out the water supply line immediately after the water pan has opened.

Note: This procedure is necessary to protect the ice dispenser from freezing up at subfreezing temperature.

- 4) Unplug the ice dispenser or disconnect the power source when the water pan has fully opened.
- 5) Clean the storage bin liner, spout, drain pan and ice station, and dry them thoroughly. See “IV. MAINTENANCE INSTRUCTIONS”.
- 6) Refit the front panel (upper), and push down its top while turning the keyhole clockwise.

### **Auxiliary code: K1 or later**

- 1) Press the push button to dispense all ice from the storage bin.
- 2) Follow the steps 1) to 5) in “1. IN CASE OF DIRTY WATER”.
- 3) Blow out the water supply line immediately after the water pan has opened.

Note: This procedure is necessary to protect the ice dispenser from freezing up at subfreezing temperature.

- 4) Unplug the ice dispenser or disconnect the power source when the water pan has fully opened.
- 5) Clean the storage bin liner, spout, drain pan and ice station, and dry them thoroughly. See “IV. MAINTENANCE INSTRUCTIONS”.
- 6) Refit the front panel and switch cover, and screw the panel in place.

## IV. MAINTENANCE INSTRUCTIONS

### **⚠ WARNING**

1. Before carrying out any cleaning or maintenance operations, unplug the ice dispenser from the electrical supply network.
2. This appliance must not be cleaned by use of a water jet.

### **⚠ CAUTION**

Before handling or using cleaning solutions, check the guidelines on the product for advice on suitable personal protective clothing, gloves, goggles, etc.

### **NOTICE**

1. Clean and sanitize the ice dispenser water system at least twice a year, and check and clean the condenser at least once a year.
2. To prevent possible damage, do not clean the plastic parts with water above 40°C or in a dishwasher.

## 1. MACHINE EXTERIOR, SPOUT, ICE STATION

Wipe the exterior, spout and ice station at least once per week with a clean, soft cloth. Use a damp cloth containing a neutral cleaner to wipe off grease or dirt.

## 2. AIR FILTER

Plastic mesh air filters remove dirt or dust from the air, and keep the condenser from getting clogged. If the filters get clogged, the ice dispenser's performance will be reduced. Remove and clean the air filter(s) at least twice per month:

- 1) Slide the air filter off the filter guide the louver.
- 2) Clean the air filter by using a vacuum cleaner. When severely clogged, use warm water and a neutral cleaner to wash the air filter.
- 3) Rinse and dry the air filter thoroughly.

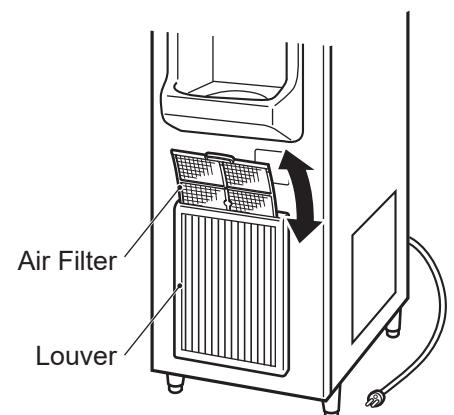

**Fig. 4**

## NOTICE

After cleaning, be sure to place the air filter back in position.

### 3. DRAIN PAN, STORAGE BIN, FRONT PANEL (UPPER)

- 1) Follow the steps 1) to 2) in “III. 2. PREPARING THE ICE DISPENSER FOR LONG STORAGE”.
- 2) Unplug the ice dispenser.
- 3) Pull out the drain pan hose from the drain hole in the storage bin.
- 4) Remove the thumbscrew at the front, and take out the drain pan from the storage bin.
- 5) Soak the drain pan in warm water containing a neutral cleaner for at least 3 minutes. Rinse thoroughly with clean water.
- 6) Wipe the backside of the front panel (upper) with a damp cloth containing a neutral cleaner. Use a clean damp cloth to wipe off the cleaner.
- 7) Wash the storage bin liner with clean water.
- 8) Refit the drain pan and front panel (upper) in their correct position. Run the bin control switch lead through the recess in the drain pan.

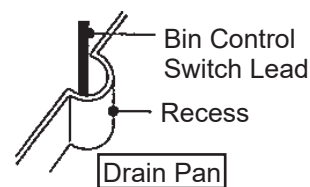

**Fig. 5**

### 4. ICE STATION, DRAIN TRAP

- 1) Lightly lift the cap at the center of the ice station and turn it counterclockwise.
- 2) Lift the cap straight off.
- 3) Soak the cap in warm water containing a neutral cleaner for at least 3 minutes. Rinse thoroughly with clean water.
- 4) Wipe the notches in the ice station with a damp cloth containing a neutral cleaner. Use a clean damp cloth to wipe off the cleaner.
- 5) Refit the cap in the ice station by fitting the tabs in the notches.
- 6) Turn the cap tightly clockwise.

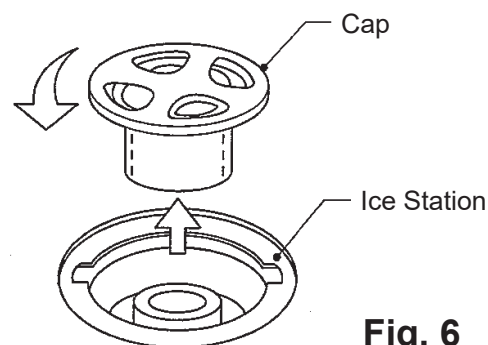

**Fig. 6**

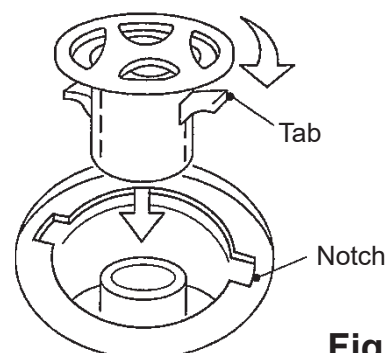

**Fig. 7**



## 5. WATER VALVE

**Auxiliary code: K0 or earlier**

- 1) Follow the steps 1) to 2) in “III. 2. PREPARING THE ICE DISPENSER FOR LONG STORAGE”.
- 2) Unplug the ice dispenser.
- 3) Disconnect the fitting nut from the water valve.
- 4) Remove the mesh filter from the water valve.
- 5) Clean the mesh using a brush.
- 6) Replace the mesh and fitting nut in their correct positions.
- 7) Open the water supply tap.
- 8) Plug in the ice dispenser or connect the power source.
- 9) Check for leaks.
- 10) Replace the panels in their correct positions.

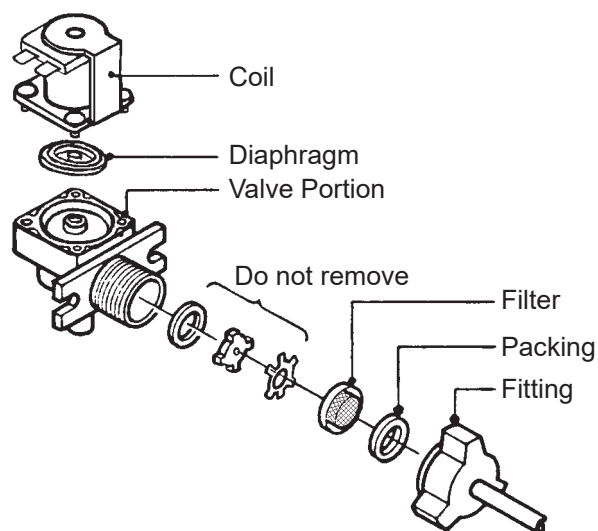

**Fig. 8**

**Auxiliary code: K1 or later**

- 1) Follow the steps 1) to 2) in “III. 2. PREPARING THE ICE DISPENSER FOR LONG STORAGE”.
- 2) Unplug the ice dispenser or disconnect the power source.
- 3) Close the water supply tap.
- 4) Remove the top panel and front panel.
- 5) Disconnect the inlet hose from the water valve.
- 6) Remove the mesh filter from the water valve.
- 7) Clean the mesh using a brush.
- 8) Replace the mesh and inlet hose in their correct positions.
- 9) Open the shut-off valve.
- 10) Plug in the ice dispenser or connect the power source.
- 11) Check for leaks.
- 12) Replace the panels in their correct positions.

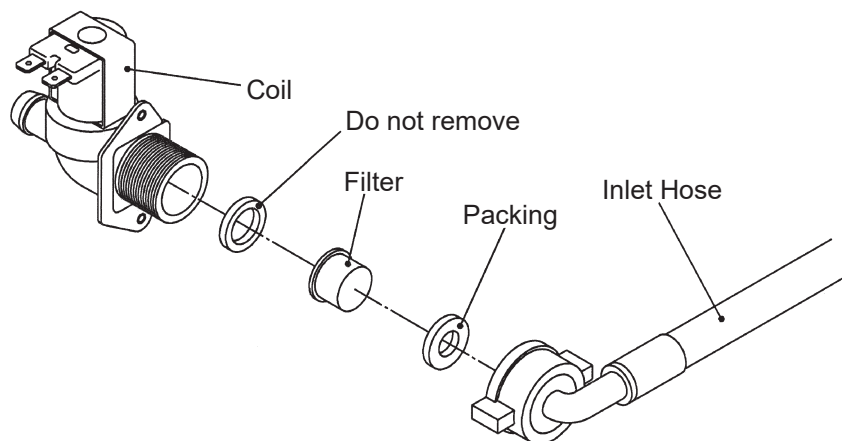

**Fig. 9**

## 6. ICEMAKING WATER SYSTEM

To keep the ice dispenser hygienic, clean and sanitize the icemaking water system at least once every six months. More frequent cleaning and sanitizing may be required depending on the water quality.

### CAUTION

Always wear rubber gloves, eye protectors, apron, etc. for safe handling of the cleaner and sanitizer.

### NOTICE

1. Use the cleaners and sanitizers recommended by Hoshizaki. Contact your local Hoshizaki office for further details. (The instructions below give an example of those recommended cleaners and sanitizers.)
2. Never mix cleaning and sanitizing solutions in an attempt to shorten cleaning time.
3. Wipe off any splashed or spilt cleaner/sanitizer immediately.
4. Do not use any ammonia type cleaners on any part of the ice dispenser.
5. When the ambient and water temperatures are 10°C or below, the water pan may remain open. Warm the icemaking compartment up to 20°C around the thermistor.
6. Be sure to follow the cleaning and sanitizing instructions below.

- 1) Use a suitable container to dilute 236 ml of the cleaner ("Nickel-Safe Ice Machine Cleaner" by The Rectorseal Corporation) with 11.4 lit. of water.
- 2) Open the storage bin door, and remove all the ice to avoid contaminating by the cleaner.
- 3) Remove the front and top panels (see "III. 1. IN CASE OF DIRTY WATER").
- 4) If the ice dispenser is in a defrost cycle, wait until a freeze cycle starts.
- 5) Close the water supply tap.
- 6) Push the reset switch to open the water pan.
- 7) Unplug the ice dispenser or disconnect the power source when the water pan has fully opened.

- 8) After the water has completely drained out, plug in the ice dispenser or connect the power source. When the 7-segment display on the controller board turns on, press DOWN on the controller board for 3 seconds to start the flush mode. (See the controller board service manual for further details.)
- 9) When the flush mode has started, pour the cleaning solution prepared in 1) carefully into the water tank within 60 seconds before the pump motor starts. Do not splash or spill the solution onto the other parts.
- 10) Allow the liquid to circulate for 30 minutes. Push the reset switch to open the water pan. Unplug the ice dispenser or disconnect the power source when the water pan has fully opened. Wait until the liquid has completely drained out.
- 11) Open the water supply tap, and repeat the above step 8), then step 10). Plug in the ice dispenser.
- 12) Repeat the above step 11) at least three times to rinse thoroughly.

### **NOTICE**

The cleaner must be completely flushed from the water circuit, or damage could occur to the plastic parts.

### **SANITIZING INSTRUCTIONS**

Note: Sanitizing should always be completed after cleaning or alternately as an individual procedure if conditions exist to make it necessary.

- 13) Use a suitable container to dilute 44 ml of 5.25% sodium hypochlorite solution with 11.4 lit. of water.
  - \* Alternatively use the Hoshizaki recommended sanitizer as directed by the relevant instructions.
- 14) Close the water supply tap. Plug in the ice dispenser or connect the power source. When the 7-segment display on the controller board turns on, press DOWN on the controller board for 3 seconds to start the flush mode.
- 15) When the flush mode has started, pour the cleaning solution prepared in 13) carefully into the water tank within 60 seconds before the pump motor starts. Do not splash or spill the solution onto the other parts.
- 16) Circulate the sanitizing solution for 15 minutes. Push the reset switch to open the water pan. Unplug the ice dispenser or disconnect the power source when the water pan has fully opened. Wait until the sanitizing solution has completely drained out.

- 17) Open the water supply tap, and repeat the above step 8), then step 10). Plug in the ice dispenser.
- 18) Repeat the above step 17) at least three times to rinse thoroughly.
- 19) Plug in the ice dispenser or connect the power source. Check for proper icemaking operation.
- 20) Complete storage bin cleaning as detailed in "IV. 3. DRAIN PAN, STORAGE BIN, FRONT PANEL (UPPER)".
- 21) Replace the front panel and top panel in their correct positions.

# V. TECHNICAL INFORMATION

## 1. WATER CIRCUIT AND REFRIGERANT CIRCUIT

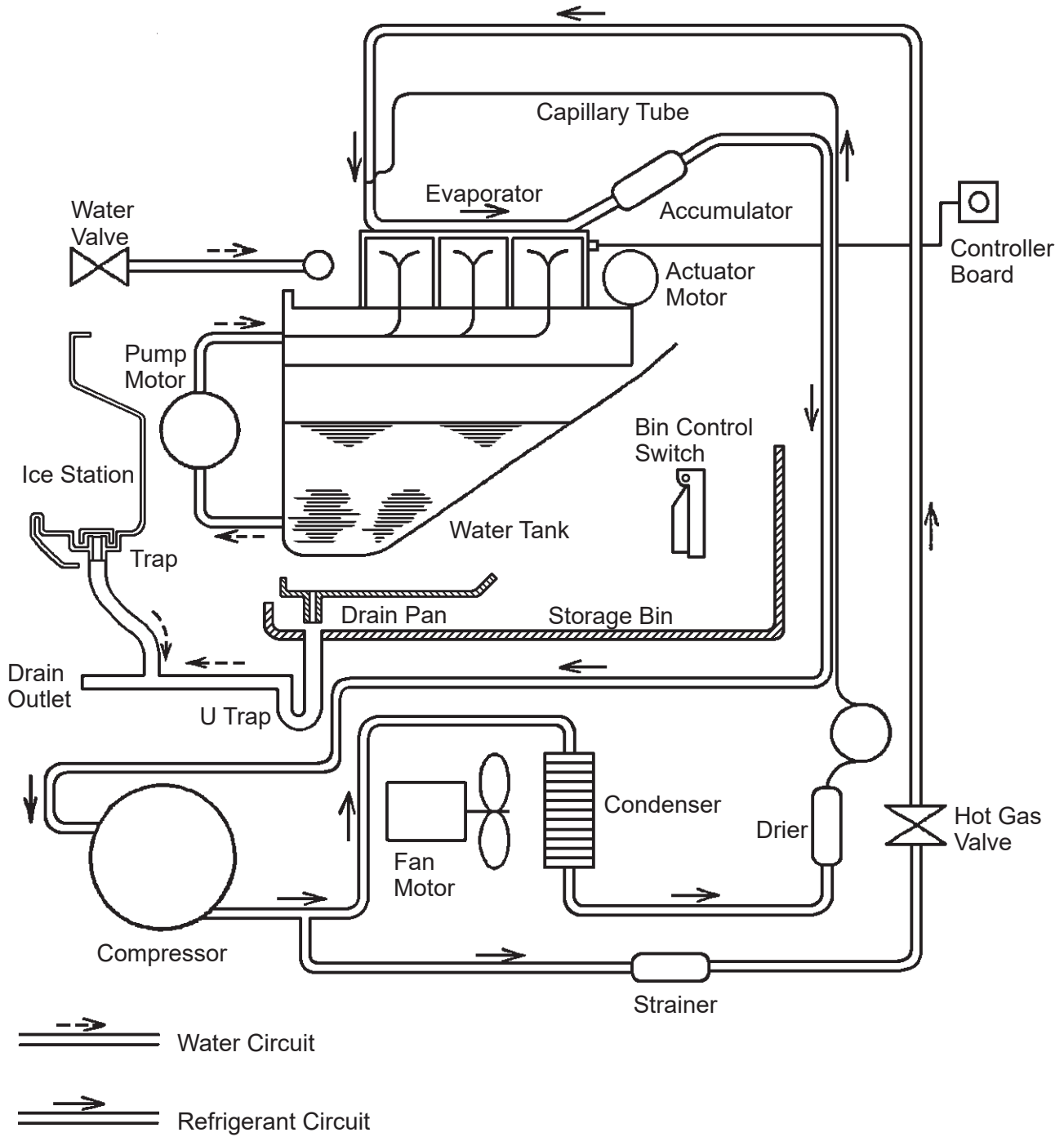

## 2. WIRING DIAGRAM

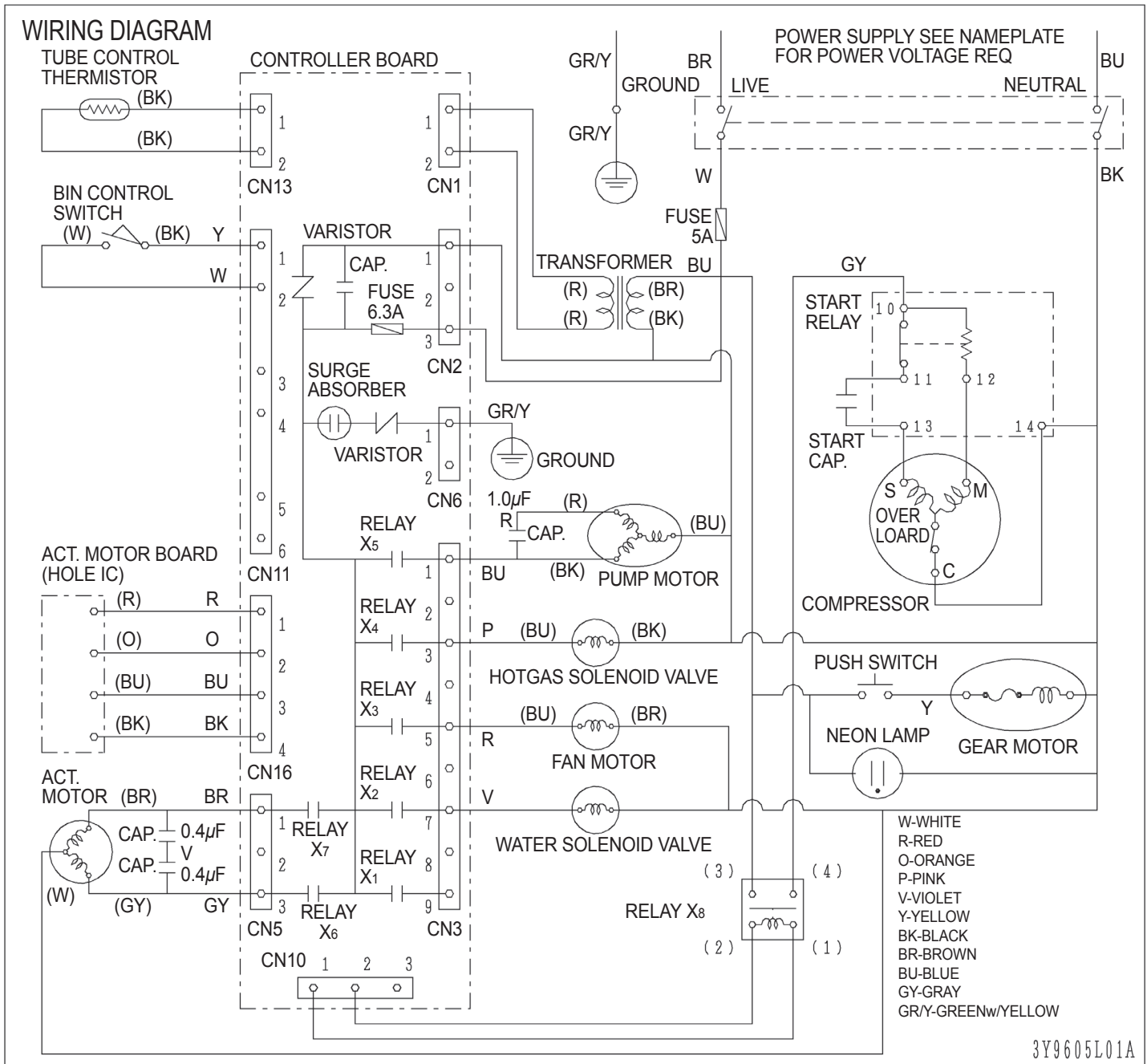

### 3. PERFORMANCE DATA

(Ice production = Capacity when shipped from factory)

|            |                      |         |        |        |        |         |
|------------|----------------------|---------|--------|--------|--------|---------|
| Model      | Ambient Temp.        | (°C)    | 10     | 21     | 32     | 38      |
|            | Water Temp.          | (°C)    | 10     | 15     | 21     | 32      |
|            | Cube Hole Diameter   | (mm)    | 5 (15) | 5 (15) | 5 (15) | 5 (15)  |
| DIM-30DE-2 | Ice Production       | (kg/d)  | 40     | 35.6   | 27.7   | 18 (20) |
|            | Freeze Cycle Time    | (min)   | 17.5   | 21.1   | 30.1   | –       |
|            | Defrost Cycle Time   | (min)   | 3.6    | 2.2    | 1.5    | –       |
|            | Water Consumption    | (lit/h) | 4.7    | 4.25   | 3.1    | –       |
|            | Electric Consumption | (W)     | 275    | 306    | 341    | –       |
|            | Head Pressure [peak] | (bar)   | –      | –      | –      | –       |

Note: The sound output of this appliance is below 70dB.



## VI. SERVICE DIAGNOSIS

### 1. NO ICE PRODUCTION

| PROBLEM  | CHECK  | POSSIBLE CAUSE  | REMEDY  |
|--|--|---|---|
| [1] The ice dispenser will not start.                      | a) Power source  | 1. OFF position.  | 1. Move to ON position.                                       |
|  |  | 2. Loose connections.   | 2. Tighten.   |
|  |  | 3. Bad contacts.  | 3. Check for continuity and replace.                          |
|  | b) Power cord  | 1. Loose connection.  | 1. Tighten.   |
|  |  | 2. Open circuit - damaged.  | 2. Repair or replace.   |
|  | c) Fuse  | 1. Blown out.   | 1. Replace.   |
|  | d) Bin control   | 1. Tripped with bin filled with ice.  | 1. Remove ice.  |
|  |  | 2. Out of position.   | 2. Place in position.   |
|  |  | 3. Fused contacts.  | 3. Check for continuity and replace.                          |
|  | e) Transformer   | 1. Coil winding opened.   | 1. Replace.   |
|  | f) Wiring to controller board  | 1. Loose connections or open.   | 1. Check for continuity and repair or replace.                |
|  | g) Thermistor  | 1. Leads short-circuit or open and high temperature safety (backup timer) operates.       | 1. See "II. 1. [c] BEFORE CHECKING CONTROLLER BOARD".         |
|  | h) Hot gas solenoid valve  | 1. Continues to open in freeze cycle and high temperature safety (backup timer) operates. | 1. Check for power OFF in freeze cycle and replace.           |
| i) Water solenoid valve                                    | 1. Mesh filter or orifice gets clogged and water supply cycle does not finish. | 1. Clean.   |   |
|  | 2. Coil winding opened.  | 2. Replace.   |   |
|  | 3. Wiring to water valve.  | 3. Check for loose connection or open, and replace.                                       |   |
| j) Controller board  | 1. Defective.  | 1. See "II. CONTROLLER BOARD".  |   |
| [2] Compressor will not start, or operates intermittently. | a) Overload protector  | 1. Bad contacts.  | 1. Check for continuity and replace.                          |
|  |  | 2. Voltage too low.   | 2. Check for recommended voltage.                             |
|  |  | 3. Refrigerant overcharged or undercharged.   | 3. Recharge.  |
|  | b) Starter   | 1. Defective.   | 1. Replace.   |
|  | c) Start capacitor or run capacitor  | 1. Defective.   | 1. Replace.   |
|  | d) Power relay   | 1. Bad contacts.  | 1. Check for continuity and replace.                          |
|  |  | 2. Coil winding opened.   | 2. Replace.   |
|  | e) Compressor  | 1. Wiring to compressor.  | 1. Check for loose connection or open, and repair or replace. |
|  |  | 2. Defective.   | 2. Replace.   |

| PROBLEM   | CHECK                                 | POSSIBLE CAUSE   | REMEDY  |
|---|---------------------------------------|--|---|
| [2] (Continued)   | f) Air filter, condenser              | 1. Clogged.  | 1. Clean.   |
| [3] Compressor runs, but other components will not start. | a) Control circuit                    | 1. Loose connection or broken wire.                                    | 1. Repair or replace.                               |
| [4] Fan motor will not run.                               | a) Wiring                             | 1. Loose connection or broken wire.                                    | 1. Repair or replace.                               |
|   | b) Actuator toggle switch             | 1. Defective.  | 1. Replace.   |
|   | c) Thermistor, controller board       | 1. See "II. CONTROLLER BOARD".   |   |
| [5] Water continues to be supplied in freeze cycle.       | a) Water solenoid valve               | 1. Diaphragm does not close.   | 1. Check for water leaks with ice dispenser OFF.    |
|   | b) Controller board                   | 1. Defective.  | 1. See "II. CONTROLLER BOARD".                      |
| [6] Water does not circulate.                             | a) Water supply line                  | 1. Water pressure too low and water level in water tank too low.       | 1. Check for recommended pressure.                  |
|   | b) Water solenoid valve               | 1. Dirty mesh filter or orifice and water level in water tank too low. | 1. Clean.   |
|   | c) Water system                       | 1. Water leaks.  | 1. Check connections for water leaks, and repair.   |
|   |                                       | 2. Clogged.  | 2. Clean.   |
|   | d) Pump motor                         | 1. Motor winding opened.   | 1. Replace.   |
|   |                                       | 2. Bearing worn out.   | 2. Replace.   |
|   |                                       | 3. Wiring to pump motor.   | 3. Check for loose connection or open, and replace. |
| 4. Defective or bound impeller.                           |                                       | 4. Replace and clean.  |   |
| e) Controller board                                       | 1. Defective.                         | 1. See "II. CONTROLLER BOARD".   |   |
| f) Discharge tube   | 1. Clogged.                           | 1. Clean.  |   |
|   | 2. Out of position.                   | 2. Place in position.  |   |
| [7] All components run, but no ice is produced.           | a) Refrigerant                        | 1. Undercharged.   | 1. Check for leaks and recharge.                    |
|   |                                       | 2. Air or moisture trapped.  | 2. Replace drier, and recharge.                     |
|   | b) Compressor                         | 1. Defective valve.  | 1. Replace compressor.                              |
| c) Hot gas solenoid valve                                 | 1. Continues to open in freeze cycle. | 1. Check and replace.  |   |
| [8] Water pan will not open.                              | a) Wiring                             | 1. Loose connection or broken wire.                                    | 1. Repair or replace.                               |
|   | b) Actuator motor, run capacitor      | 1. Defective.  | 1. Replace.   |
|   | c) Thermistor, controller board       | 1. See "II. CONTROLLER BOARD".   |   |
| [9] Water pan will not close.                             | a) See [8] above.                     |  |   |
|   | b) Hot gas valve                      | 1. Defective.  | 1. Replace.   |

## 2. LOW ICE PRODUCTION

| PROBLEM                                    | CHECK                           | POSSIBLE CAUSE                                    | REMEDY  |
|--|---------------------------------|---|---|
| [1] Freeze cycle time is too long.         | a) Water supply                 | 1. Low pressure.                                  | 1. Check for recommended pressure.            |
|  | b) Water temperature            | 1. Too high.                                      | 1. Check for recommended water temperature.   |
|  | c) Water quality                | 1. High hardness or contains impurities.          | 1. Install a water filter or scale treatment. |
|  |                                 | 2. Lime is deposited inside cooling water tubing. | 2. Clean.                                     |
|  | d) Refrigerant charge           | 1. Overcharged or undercharged.                   | 1. Recharge correctly and check for leaks.    |
|  | e) Refrigerant circuit          | 1. Excessive moisture.                            | 1. Replace drier and recharge correctly.      |
|  | f) Thermistor, controller board | 1. See "II. CONTROLLER BOARD".                    |   |
| g) Air filter, condenser                   | 1. Clogged.                     | 1. Clean.   |   |
| [2] Takes too long for water pan to close. | a) Evaporator                   | 1. Scaled up.                                     | 1. Clean or remove scale.                     |
|  | b) Refrigerant charge           | 1. Undercharged.                                  | 1. Check for leaks and recharge correctly.    |
|  | c) Hot gas valve                | 1. Defective.                                     | 1. Replace.                                   |
|  | d) Thermistor, controller board | 1. See "II. CONTROLLER BOARD".                    |   |
|  | e) Fan motor                    | 1. Runs during defrost cycle.                     | 1. Check wiring.                              |

## 3. ABNORMAL ICE

| PROBLEM               | CHECK                           | POSSIBLE CAUSE                                    | REMEDY  |
|-----------------------|---------------------------------|---|---|
| [1] Large-hole cubes. | a) Water supply line            | 1. Low pressure.                                  | 1. Check for recommended pressure.            |
|                       | b) Ambient or water temperature | 1. Too high.                                      | 1. Check for recommended temperatures.        |
|                       | c) Air filter, condenser        | 1. Clogged.                                       | 1. Clean.                                     |
|                       | d) Water valve                  | 1. Clogged.                                       | 1. Clean.                                     |
|                       | e) Pump motor                   | 1. Leaks.   | 1. Repair or replace.                         |
|                       | f) Refrigerant charge           | 1. Undercharged.                                  | 1. Check for leaks and recharge correctly.    |
|                       | g) Thermistor, controller board | 1. See "II. CONTROLLER BOARD".                    |   |
| [2] Cloudy cubes.     | a) Water supply line            | 1. Low pressure.                                  | 1. Check for recommended pressure.            |
|                       |                                 | 2. Clogged.                                       | 2. Check strainer and clean.                  |
|                       | b) Water quality                | 1. High hardness or contains impurities.          | 1. Install a water filter or scale treatment. |
|                       |                                 | 2. Lime is deposited inside cooling water tubing. | 2. Clean.                                     |
|                       | c) Water valve                  | 1. Clogged.                                       | 1. Clean.                                     |
|                       | d) Water system                 | 1. Scaled up.                                     | 1. Clean or remove scale.                     |
| e) Water plate        | 1. Jet hole clogged.            | 1. Clean.   |   |

| PROBLEM                                      | CHECK   | POSSIBLE CAUSE                 | REMEDY                    |
|--|---|--------------------------------|---------------------------|
| [2] (Continued)                              | f) Pump motor                                   | 1. Leaks.                      | 1. Replace.               |
|  |   | 2. Bearings worn out.          | 2. Replace.               |
|  | g) Thermistor, controller board                 | 1. See "II. CONTROLLER BOARD". |                           |
| [3] Slab does not break into separate cubes. | a) Extension spring                             | 1. Over-extended.              | 1. Replace.               |
|  | b) Clearance between evaporator and water plate | 1. Too much.                   | 1. Readjust.              |
|  | c) Evaporator                                   | 1. Dirty or scaled up.         | 1. Clean or remove scale. |
|  | d) Thermistor, controller board                 | 1. See "II. CONTROLLER BOARD". |                           |

#### 4. OTHERS

| PROBLEM  | CHECK                                     | POSSIBLE CAUSE                     | REMEDY                               |
|--|---|------------------------------------|--------------------------------------|
| [1] Ice dispenser will not stop when bin is filled with ice. | a) Bin control switch                     | 1. Out of position.                | 1. Place in position.                |
|  |   | 2. Bad contacts.                   | 2. Check for continuity and replace. |
|  | b) Controller board                       | 1. See "II. CONTROLLER BOARD".     |                                      |
| [2] Abnormal noise   | a) Pump motor                             | 1. Bearing worn out.               | 1. Replace.                          |
|  | b) Actuator motor                         | 1. Gears worn out.                 | 1. Replace.                          |
|  | c) Fan motor                              | 1. Bearings worn out.              | 1. Replace.                          |
|  |   | 2. Fan blade deformed.             | 2. Replace fan blade.                |
|  |   | 3. Fan blade does not move freely. | 3. Replace.                          |
| d) Compressor  | 1. Mounting pad out of position.          | 1. Reinstall.                      |                                      |
| e) Refrigerant lines   | 1. Rubbing or touching on other surfaces. | 1. Secure or reset pipes.          |                                      |
| [3] Ice in storage bin often melts.                          | a) Bin drain                              | 1. Plugged.                        | 1. Clean.                            |

## VII. REMOVAL AND REPLACEMENT OF COMPONENTS

### 1. PANELS

#### **[a] FRONT PANEL (UPPER) (Auxiliary code: K0 or earlier)**

- 1) Unlock the front panel (upper) by turning the keyhole counterclockwise with a flat blade screwdriver. Unscrew and lift off the front panel (upper). See Fig. 1 in “III. 1. IN CASE OF DIRTY WATER”.
- 2) To refit the front panel (upper), push down the top while turning the keyhole clockwise. See Fig. 2 in “III. 1. IN CASE OF DIRTY WATER”.

#### **[b] FRONT PANEL (LOWER) (Auxiliary code: K0 or earlier)**

- 1) Remove the louver, and turn off the power switch.
- 2) Remove the front panel (upper).
- 3) Remove the two screws securing the top of the front panel (lower).
- 4) Tilt the top of the front panel (lower) slightly toward you, and lift it off.
- 5) Disconnect the drain hose from the ice station.
- 6) Remove the connectors from the front panel (lower).
- 7) To refit the front panel (lower), reconnect the connectors and drain hose, put the bottom into the unit base, and secure the top with the screws.

#### **[c] FRONT PANEL (Auxiliary code: K1 or later)**

- 1) Remove the louver, and turn off the power switch.
- 2) Remove the screw securing the bottom of the front panel.
- 3) Remove the front panel. See Fig. 3 in “III. 1. IN CASE OF DIRTY WATER”.
- 4) Disconnect the drain hose from the ice station.
- 5) Remove the connectors from the front panel.
- 6) To refit the front panel, reconnect the connectors and drain hose, hook the top onto the top panel, and secure the top with the screws.

## **[d] TOP PANEL**

- 1) Remove the front panel (upper).
- 2) Unscrew and unhook the rear of the top panel, and lift it off.
- 3) To refit the top panel, check that the insulation panel is securely in place before hooking the backside square hole of the top panel on the rear of the cabinet.

## **[e] AIR GUIDE**

The air guide fitted with a vibration damper on backside is located at the front of the condenser to prevent noise from the machine compartment.

- 1) Remove the four machine screws securing the air guide to the cabinet.
- 2) To refit the air guide, reverse the above procedure.

## **[f] REFRIGERATOR COVERS**

### **Auxiliary code: K0 or earlier**

The refrigerator covers (A) and (B) are located on top of the machine compartment as partitions and fitted with the control box.

- 1) Remove the air guide.
- 2) Remove the four machine screws securing the refrigerator cover (A), and take it off.
- 3) Remove the machine screw securing the control box, and pull out the control box.
- 4) Remove the two machine screws securing the refrigerator cover (B), and take it off.
- 5) To refit the refrigerator covers, reverse the above procedure.

### **Auxiliary code: K1 or later**

The refrigerator cover is located on top of the machine compartment as a partition and fitted with the control box.

- 1) Remove the air guide.
- 2) Remove the two machine screws securing the control box, and pull out the control box.

- 3) Remove the four machine screws securing the refrigerator cover, and take it off.
- 4) To refit the refrigerator covers, reverse the above procedure.

### [g] SWITCH BOX

The switch box is located at the top of the refrigerator cover (A) to enclose the power switch.

- 1) Remove the four machine screws securing the switch box.
- 2) To refit the switch box, reverse the above procedure.

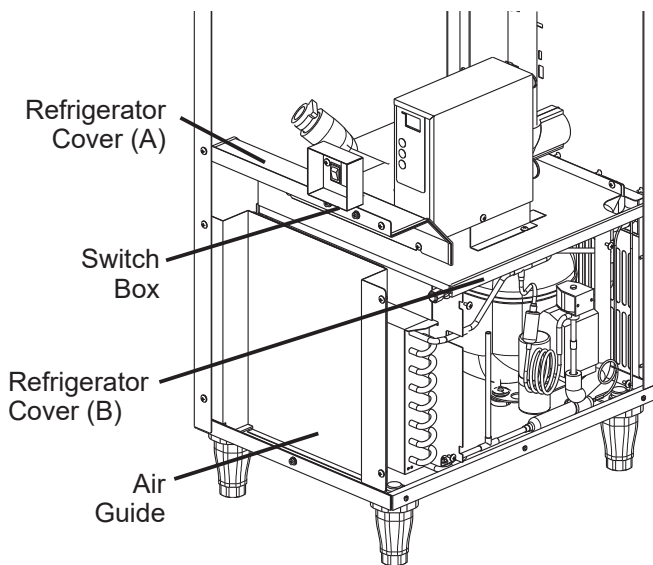

**Auxiliary code: K0 or earlier**

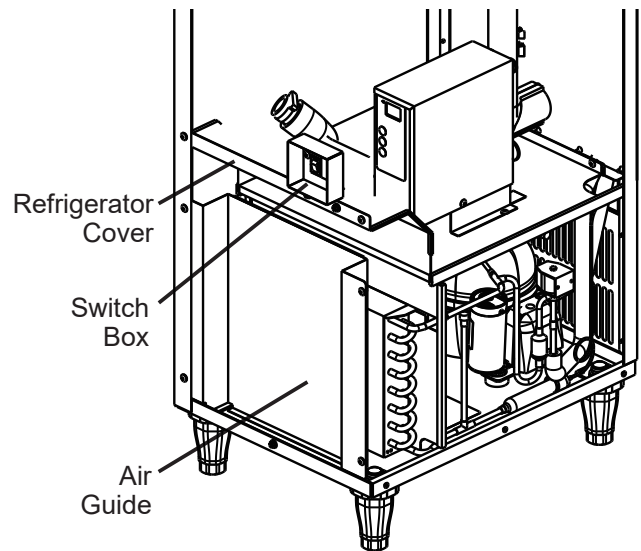

**Auxiliary code: K1 or later**

**Fig. 10**

## **2. SERVICE FOR REFRIGERANT LINES**

### **[a] SERVICE INFORMATION**

#### **1) Allowable Compressor Opening Time and Prevention of Lubricant Mixture [R134a]**

The compressor must not be opened more than 30 minutes in replacement or service. Do not mix lubricants of different compressors even if both are charged with the same refrigerant, except when they use the same lubricant.

#### **2) Treatment for Refrigerant Leak [R134a]**

If a refrigerant leak occurs in the low side of an ice maker, air may be drawn in. Even if the low side pressure is higher than the atmospheric pressure in normal operation, a continuous refrigerant leak will eventually lower the low side pressure below the atmospheric pressure and will cause air suction. Air contains a large amount of moisture, and ester oil easily absorbs a lot of moisture. If an ice maker charged with R134a has possibly drawn in air, the drier must be replaced. Be sure to use a drier designed for R134a.

#### **3) Handling of Handy Flux [R134a]**

Repair of the refrigerant circuit needs brazing. It is no problem to use the same handy flux that has been used for the current refrigerants. However, its entrance into the refrigerant circuit should be avoided as much as possible.

#### **4) Oil for Processing of Copper Tubing [R134a]**

When processing the copper tubing for service, wipe off oil, if any used, by using alcohol or the like. Do not use too much oil or let it into the tubing, as wax contained in the oil will clog the capillary tubing.

#### **5) Service Parts for R134a**

Some parts used for refrigerants other than R134a are similar to those for R134a. But never use any parts unless they are specified for R134a because their endurance against the refrigerant has not been evaluated. Also, for R134a, do not use any parts that have been used for other refrigerants. Otherwise, wax and chlorine remaining on the parts may adversely affect R134a.

#### **6) Replacement Copper Tubing [R134a]**

The copper tubes currently in use are suitable for R134a. But do not use them if oily inside. The residual oil in copper tubes should be as little as possible. (Low residual oil type copper tubes are used in the shipped units.)



## **7) Evacuation, Vacuum Pump and Refrigerant Charge [R134a]**

Never allow the oil in the vacuum pump to flow backward. The vacuum level and vacuum pump may be the same as those for the current refrigerants. However, the rubber hose and gauge manifold to be used for evacuation and refrigerant charge should be exclusively for R134a.

## **8) Refrigerant Leak Check**

Refrigerant leaks can be detected by charging the unit with a little refrigerant, raising the pressure with nitrogen and using an electronic detector. Do not use air or oxygen instead of nitrogen for this purpose, or rise in pressure as well as in temperature may cause R134a to suddenly react with oxygen and explode. Be sure to use nitrogen to prevent explosion.

## **[b] REFRIGERANT RECOVERY**

The refrigerant must be recovered in methods in compliance with the European F-gas regulation. Recover the refrigerant from the access valve, and store it in a proper container. Do not discharge the refrigerant into the atmosphere. This is a fineable offence.

When replacing the drier, take the opportunity to also fit a high-side access valve for ease of charging liquid refrigerant.

Note: Replacement refrigerant may not be available for sale due to the phase-out under the European F-gas regulation.

## **[c] EVACUATION AND RECHARGE**

- 1) Attach charging hoses, a service manifold and a vacuum pump to the system. If possible, use quick release connectors onto the access valves (especially on the high side).
- 2) Turn on the vacuum pump.
- 3) Allow the vacuum pump to pull down to a 760 mmHg vacuum. Evacuating period depends on the pump capacity.
- 4) Close the low-side and high-side valves on the service manifold.
- 5) Disconnect the vacuum pump, and attach a refrigerant charging cylinder to accurately weigh in the liquid charge. Remember to purge any air from the charging hose. See the nameplate for the required refrigerant charge.

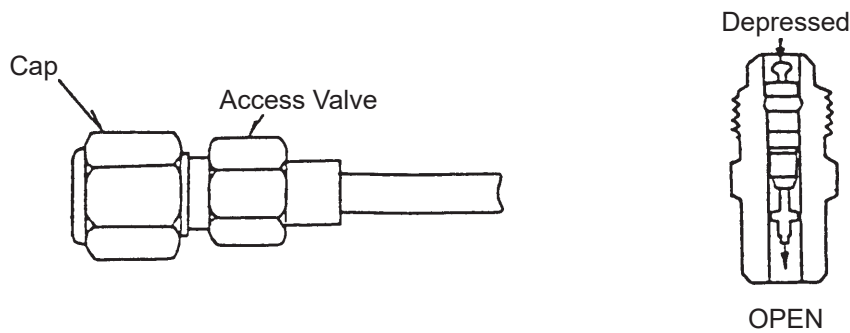

**Fig. 11**

- 6) Open the high-side valve on the gauge manifold, and accurately measure in the liquid charge. Close the valve on the charging cylinder before closing the high-side manifold valve. Any remaining liquid in the line can be charged into the low side.

Note: Always charge in the liquid stage, as many refrigerants are blends and vapour charging will affect the blend consistency.

- 7) Turn on the ice dispenser. Release the high-side access connector, and allow pressure in the charging line to slowly enter the low side of the system. Cap off the high-side access valve. When pressure reduces on the low side, disconnect the low side charging line and cap off the access valve.
- 8) Always cap the access valves to prevent a refrigerant leak.
- 9) Always thoroughly leak test all joints and valve caps.
- 10) Avoid charging large quantities of liquid into the low side in case of damage to the compressor.

### **3. COMPRESSOR**

- 1) Unplug the ice dispenser or disconnect the power source.
- 2) Remove the front panel (lower) and rear access panel.
- 3) Recover the refrigerant and store it in a proper container, if required by an applicable law (See "2. [b] REFRIGERANT RECOVERY").
- 4) Remove the terminal cover on the compressor, and disconnect solderless terminals.
- 5) Disconnect the discharge and suction pipes using brazing equipment.
- 6) Remove the hold-down bolts, washers and rubber grommets.
- 7) Slide and remove the compressor. Unpack the new compressor package.

- 8) Attach the rubber grommets of the previous compressor.
- 9) Clean the suction and discharge pipes with an abrasive cloth/paper.
- 10) Place the compressor in position, and secure it using the bolts and washers.
- 11) Remove plugs from the compressor suction and discharge pipes.
- 12) Braze or solder the access, suction and discharge lines (Do not change this order), with nitrogen gas flowing at a pressure of 0.2 - 0.3 bar.
- 13) Install the new drier (See "4. DRIER").
- 14) Check for leaks using nitrogen gas (10 bar) and soap bubbles.
- 15) Evacuate the system and charge it with refrigerant (See "2. [c] EVACUATION AND RECHARGE").
- 16) Connect the solderless terminals and replace the terminal cover in its correct position.
- 17) Replace the front panel and rear access panel in their correct positions.
- 18) Plug in the ice dispenser or connect the power source.

Note: Hoshizaki recommends that compressor starting electrics are always replaced at the same time as the compressor.

#### **4. DRIER**

- 1) Unplug the ice dispenser or disconnect the power source.
- 2) Remove the rear access panel.
- 3) Recover the refrigerant and store it in a proper container, if required by an applicable law (See "2. [b] REFRIGERANT RECOVERY").
- 4) Remove the drier holder, if any, and pull the drier toward you for easy service.
- 5) Remove the drier using brazing equipment.
- 6) Braze or solder the new drier, with the arrow on the drier in the direction of the refrigerant flow. Use nitrogen gas at a pressure of 0.2 - 0.3 bar when brazing tubings. Braze in an access valve using a tee if necessary.
- 7) Check for leaks using nitrogen gas (10 bar) and soap bubbles.

- 8) Evacuate the system and charge it with refrigerant (See “2. [c] EVACUATION AND RECHARGE”).
- 9) Replace the rear access panel in its correct position.
- 10) Plug in the ice dispenser or connect the power source.

Note: Always use a drier of the correct capacity and refrigerant type.

## 5. EVAPORATOR

### IMPORTANT

Always install a new drier every time the sealed refrigeration system is opened. Do not replace the drier until after all other repair or replacement has been made.

- 1) Unplug the ice dispenser or disconnect the power source.
- 2) Remove the top, front (upper) and rear access panels.
- 3) Recover the refrigerant and store it in a proper container, if required by an applicable law (See “2. [b] REFRIGERANT RECOVERY”).
- 4) Remove the water pan assembly, referring to “7. WATER PAN ASSEMBLY”.
- 5) Disconnect the solder connections on the evaporator using brazing equipment.
- 6) Remove the four nuts holding the evaporator.
- 7) Install the new evaporator, and secure it with the bolts, collars (spacers) and nuts.
- 8) Remove and replace the drier (See “4. DRIER”).
- 9) Braze pipes, with nitrogen gas flowing at a pressure of 0.2 - 0.3 bar.
- 10) Check for leaks using nitrogen gas (10 bar) and soap bubbles.
- 11) Evacuate the system and charge it with refrigerant (See “2. [c] EVACUATION AND RECHARGE”).
- 12) Replace the panels in their correct positions.
- 13) Plug in the ice dispenser or connect the power source.

## 6. HOT GAS VALVE

### IMPORTANT

Always install a new drier every time the sealed refrigeration system is opened. Do not replace the drier until after all other repair or replacement has been made.

- 1) Unplug the ice dispenser or disconnect the power source.
- 2) Remove the rear access panel.
- 3) Recover the refrigerant and store it in a proper container, if required by an applicable law (See “2. [b] REFRIGERANT RECOVERY”).
- 4) Disconnect the hot gas valve leads.
- 5) Remove the screw and the solenoid coil.
- 6) Remove the valve and drier using brazing equipment.
- 7) Braze the new hot gas valve with nitrogen gas flowing at a pressure of 0.2 - 0.3 bar.

### WARNING

Always protect the valve body by using a damp cloth to prevent the valve from overheating. Do not braze with the valve body exceeding 120°C.

- 8) Install the new drier (See “4. DRIER”).
- 9) Check for leaks using nitrogen gas (10 bar) and soap bubbles.
- 10) Evacuate the system and charge it with refrigerant (See “2. [c] EVACUATION AND RECHARGE”).
- 11) Attach the solenoid coil to the valve body, and secure it with the screw.
- 12) Connect the leads.
- 13) Replace the panels in their correct positions.
- 14) Plug in the ice dispenser or connect the power source.

## 7. WATER PAN ASSEMBLY

- 1) Remove the top panel and front panel (upper).
- 2) Remove the front panel (lower), and push the reset switch on the control box to open the water pan.
- 3) Unplug the ice dispenser or disconnect the power source.
- 4) Disconnect the pump motor leads in the wiring channel.
- 5) Remove the two extension springs from the cam arms.
- 6) Remove the water pan brackets and the water pan assembly.
- 7) Remove the two spring hook screws from the water tank.
- 8) Remove the screws and the water pan brackets.
- 9) Remove the pump suction and discharge tubings.
- 10) Remove the pump motor bracket from the water plate.
- 11) Install the new water plate or water tank in the reverse order of the removal procedure.
- 12) Replace the panels in their correct positions.
- 13) Plug in the ice dispenser or connect the power source.

| INDEX NO. | DESCRIPTION           |
|-----------|-----------------------|
| 1         | Water Plate           |
| 2         | Water Tank            |
| 3         | Drain Guide           |
| 4         | Spring Hook Screw     |
| 5         | Water Pan Bracket (A) |
| 6         | Water Pan Bracket (B) |
| 7         | Pump Motor            |
| 8         | Suction Tubing        |
| 9         | Discharge Tubing      |
| 10        | Lubrication Plate     |
| 11        | Silicone Tube         |
| 12        | Tie                   |

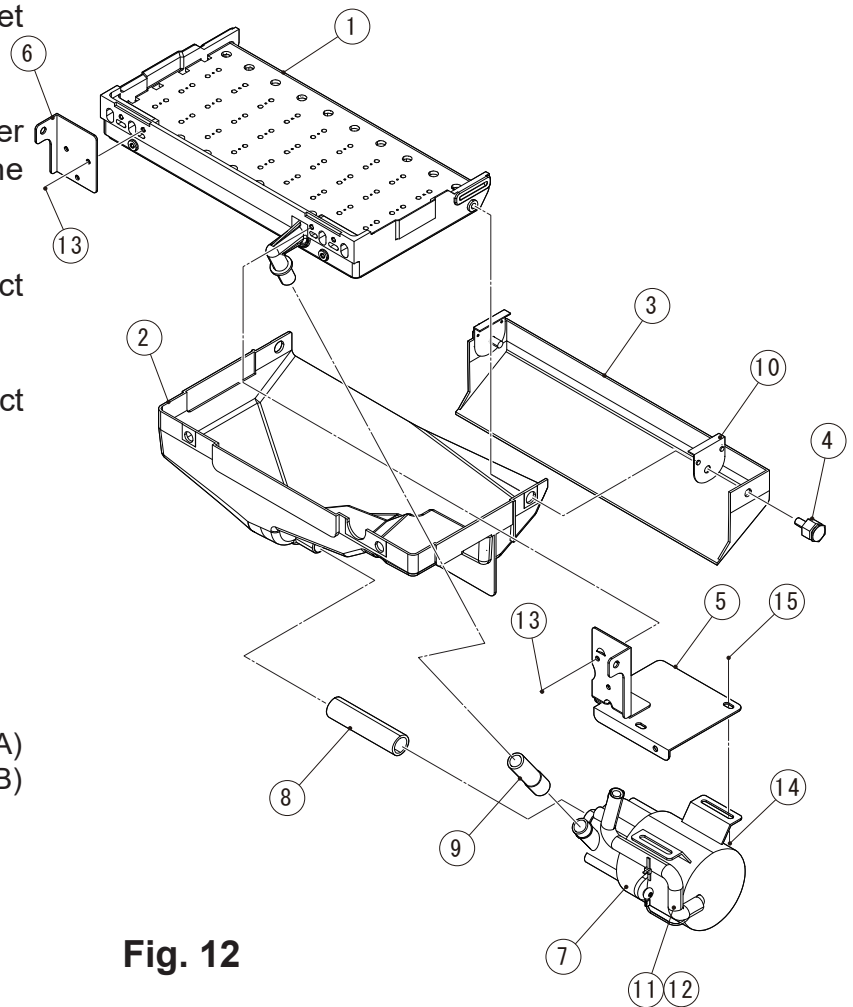

**Fig. 12**

## **8. PUMP MOTOR**

- 1) Unplug the ice dispenser or disconnect the power source.
- 2) Remove the top panel and front panel (upper).
- 3) Disconnect the pump motor leads in the wiring channel.
- 4) Remove screws and the pump motor from the bracket.
- 5) Disconnect the pump suction and discharge tubings.
- 6) Disassemble the pump motor and check the motor or parts.
- 7) Install the new motor or parts in the reverse order of the removal procedure.
- 8) Plug in the ice dispenser or connect the power source, and check for leaks.
- 9) Replace the panels in their correct positions.

## **9. WATER VALVE**

- 1) Close the water supply tap.
- 2) Unplug the ice dispenser or disconnect the power source.
- 3) Remove the top panel and front panel.
- 4) Disconnect the receptacle (leads) from the water valve.
- 5) Remove the valve outlet tubing by releasing the clamp.
- 6) Remove the inlet hose and water valve.
- 7) Install the new valve in the reverse order of the removal procedure.
- 8) Open the water supply tap.
- 9) Plug in the ice dispenser or connect the power source.
- 10) Check for leaks.
- 11) Replace the top panel in its correct position.

Note: When replacing parts, disassemble as shown in Figs. 8 and 9 and replace the defective parts.

## 10. ACTUATOR MOTOR

- 1) Remove the top panel and front panel (upper).
- 2) Push the reset switch on the control box to open the water pan.
- 3) Unplug the ice dispenser or disconnect the power source.
- 4) Remove the extension spring (actuator motor side) from the cam.
- 5) Disconnect the actuator motor leads in the wiring channel.
- 6) Remove the actuator motor bracket.
- 7) Remove the spring pin securing the shaft to the cam.
- 8) Remove the actuator motor.
- 9) Install the new actuator motor in the reverse order of the removal procedure.
- 10) Check that the cam can move in the proper range.
- 11) Replace the panels in their correct positions.
- 12) Plug in the ice dispenser or connect the power source.

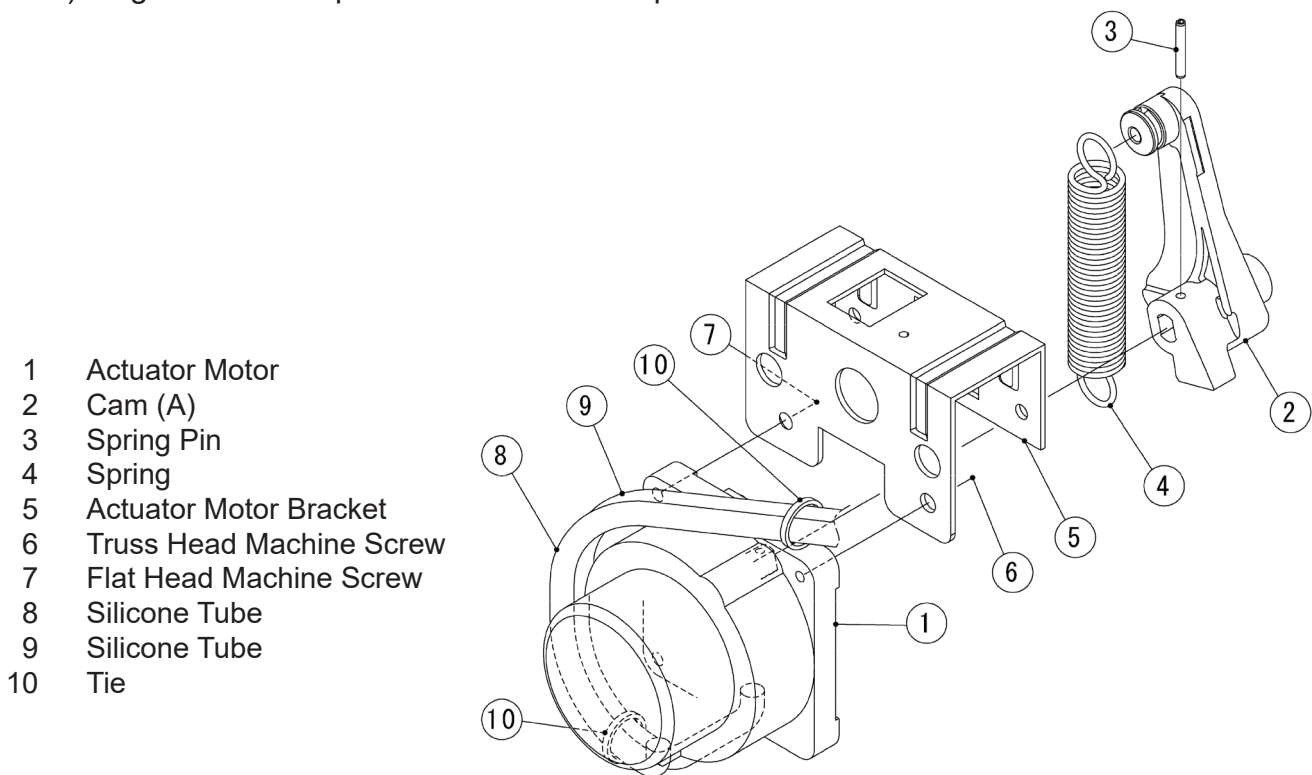

**Fig. 13**



## **11. CAM ARM**

### **[a] CAM ARM (A) - ACTUATOR MOTOR SIDE**

Refer to "10. ACTUATOR MOTOR".

### **[b] CAM ARM (B) - REAR SIDE**

- 1) Remove the top panel and front panel (upper).
- 2) Remove the front panel (lower), and push the reset switch on the control box to open the water pan.
- 3) Unplug the ice dispenser or disconnect the power source.
- 4) Remove the extension spring from the cam arm (B).
- 5) Remove the split pin from the cam shaft.
- 6) Remove the cam arm (B).
- 7) Install the new cam in the reverse order of the removal procedure.
- 8) Replace the panels in their correct positions.
- 9) Plug in the ice dispenser or connect the power source.

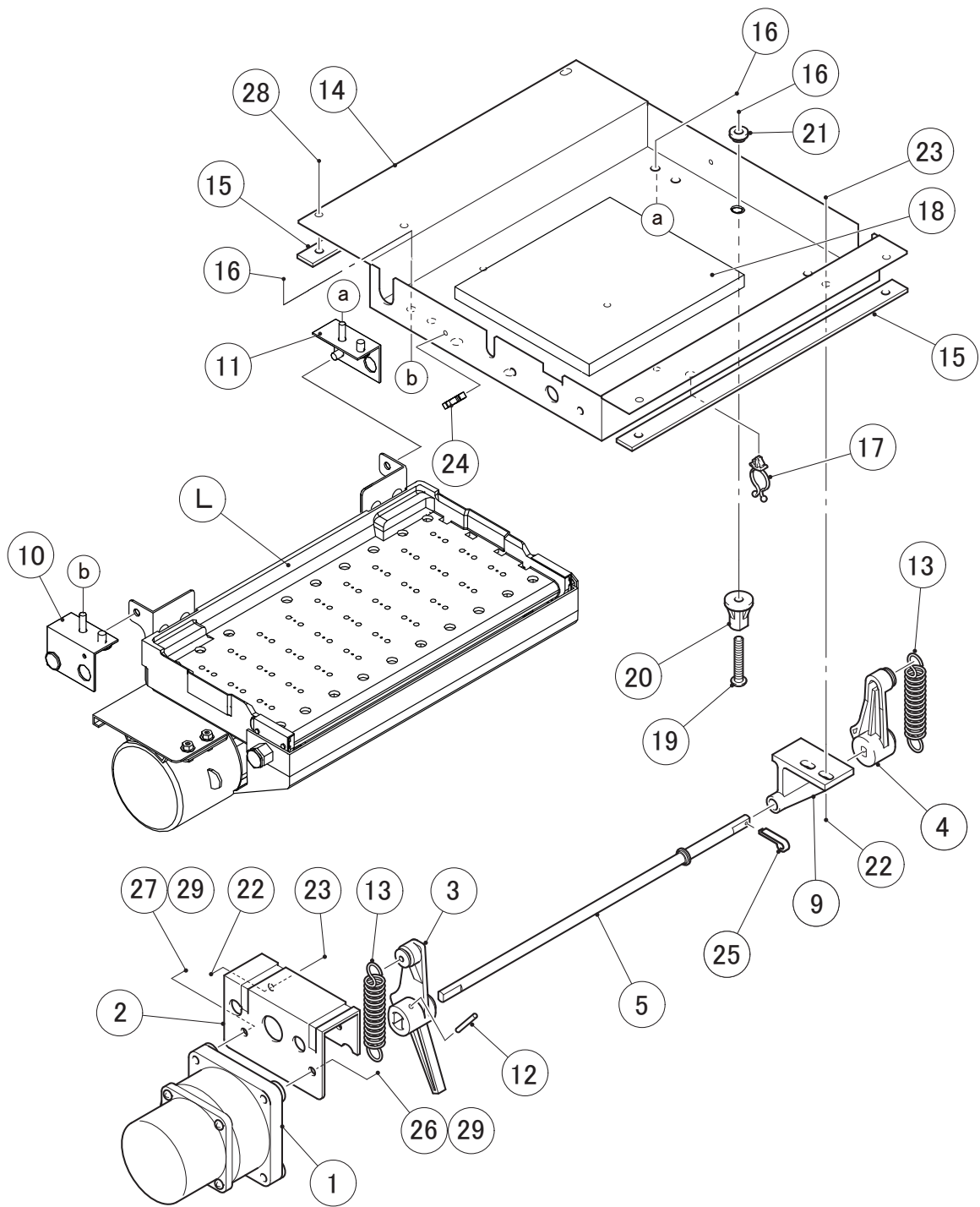

**Fig. 14**

## ICEMAKING ASSEMBLY AND CAM MECHANISM

| INDEX NO. | DESCRIPTION               |
|-----------|---------------------------|
| L         | Water Pan Assembly        |
| 1         | Actuator Motor            |
| 2         | Actuator Motor Bracket    |
| 3         | Cam Arm (A)               |
| 4         | Cam Arm (B)               |
| 5         | Cam Shaft                 |
| 9         | Cam Shaft Bearing         |
| 10        | Water Pan Bearing (A)     |
| 11        | Water Pan Bearing (B)     |
| 12        | Spring Pin                |
| 13        | Extension Spring          |
| 14        | Mechanism Base            |
| 15        | Spacer                    |
| 16        | Flange Nut                |
| 17        | Clamp                     |
| 18        | Insulation                |
| 19        | Evaporator Mounting Screw |
| 20        | Spacer                    |
| 21        | Washer                    |
| 25        | Split Pin                 |

## 12. CONTROLLER BOARD

### IMPORTANT

A single type controller board is supplied as a service board. Some modifications and adjustment will be required to fit the ice dispenser models. Do not repair any parts and electronic devices on the controller board in the field. Replace the whole board with a new service board.

### [a] MODIFICATION

1) Check that the service board package includes:

|                   |       |
|-------------------|-------|
| Controller Board  | 1 pc. |
| Label             | 1 pc. |
| Instruction Sheet | 1 pc. |

2) Modify the service board referring to the instruction sheet attached.

## [b] REPLACEMENT

- 1) Unplug the ice dispenser or disconnect the power source.
- 2) Remove the front panel (lower).
- 3) Remove screws and the control box cover.
- 4) Pull out and remove the controller board from the control box.
- 5) Install the new controller board and reassemble the control box in the reverse order of the removal procedure.
- 6) Replace the panel in its correct position.
- 7) Plug in the ice dispenser or connect the power source.

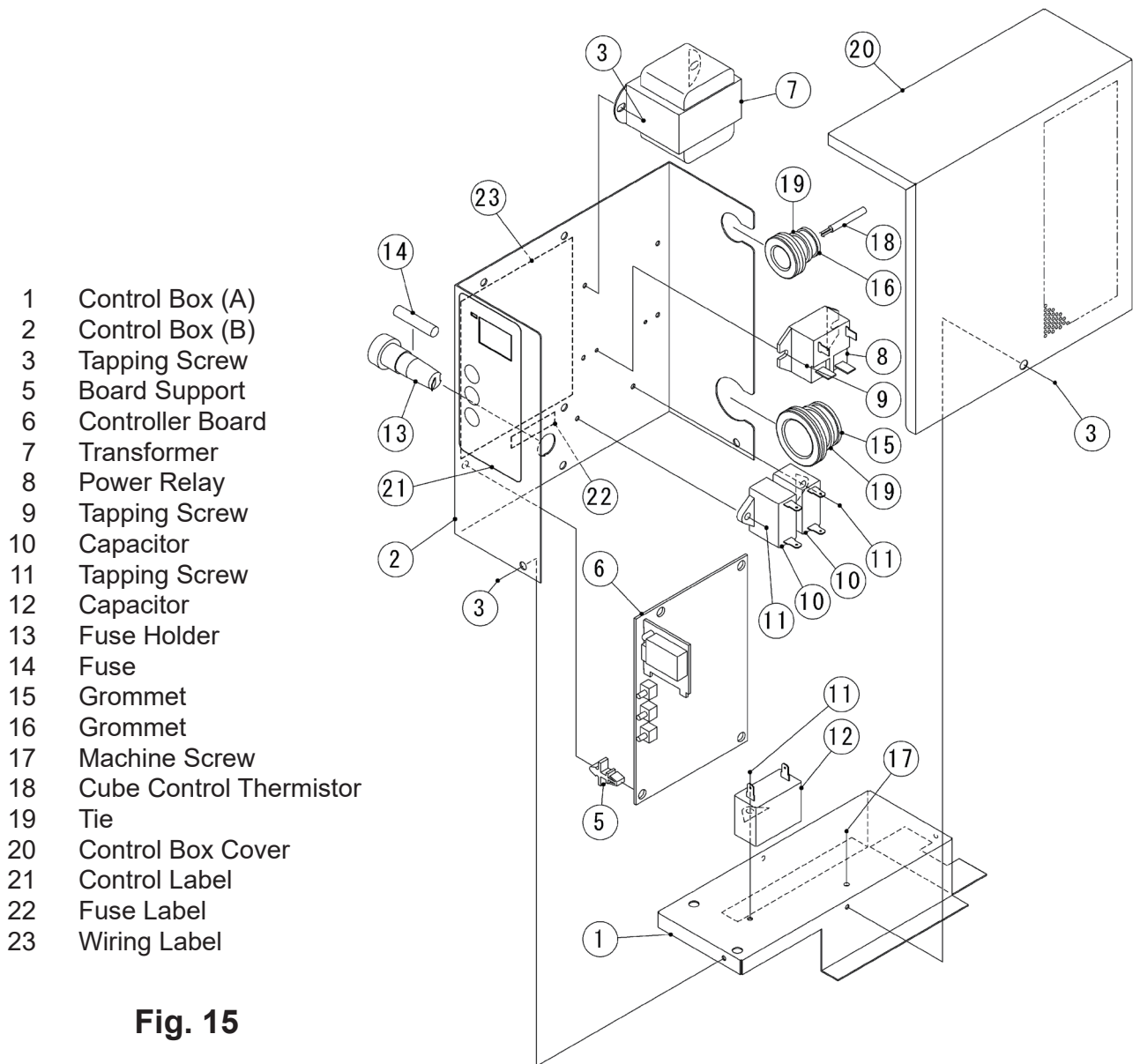
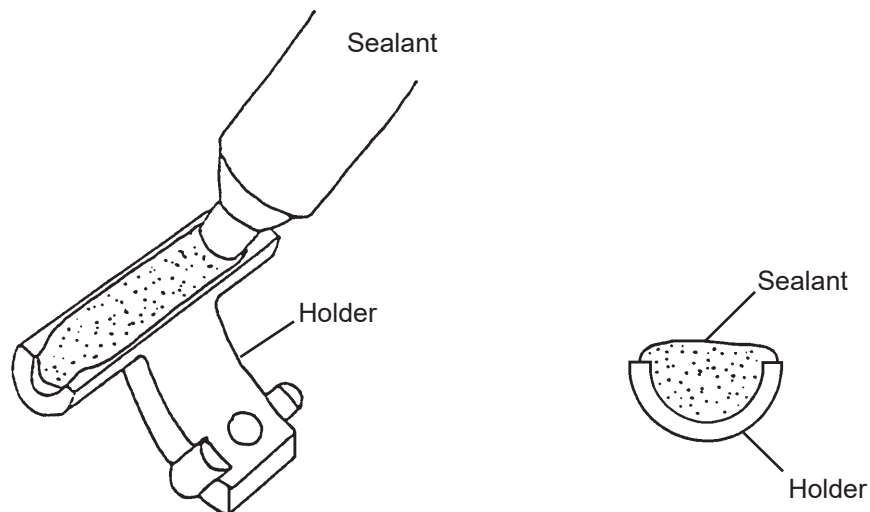

**Fig. 15**

### 13. THERMISTOR FOR CUBE CONTROL

- 1) Unplug the ice dispenser or disconnect the power source.
- 2) Remove the top panel, front panel and pipe cover (rear).
- 3) Remove the connector K4 on the controller board, referring to “12. [b] REPLACEMENT”.
- 4) Unscrew and remove the thermistor holder and thermistor, located on the evaporator (front side).
- 5) Install the new thermistor in the reverse order of the removal procedure, by using a sealant (high-thermal conduct type). See Fig. 16.

Note: Recommended sealant is KE4560RTV, manufactured by Shin-Etsu Silicones. When other type of sealant used, the cube size and performance will be changed. Do not use silicone sealant as this will insulate the thermistor.



\* Thermistor and leads are FRAGILE.  
HANDLE WITH CARE.

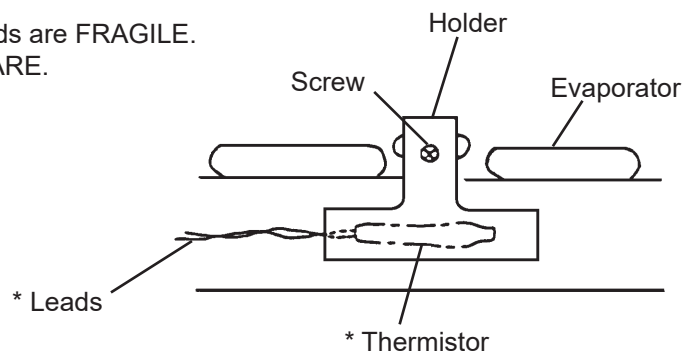

**Fig. 16**

## **14. FAN MOTOR**

- 1) Unplug the ice dispenser or disconnect the power source.
- 2) Remove the front panel (lower).
- 3) Remove the control box and air guide.
- 4) Disconnect the connector of the fan motor.
- 5) Remove the fan motor bracket and the fan motor.
- 6) Cut the leads of the fan motor allowing enough lead length to reconnect using closed end connectors.
- 7) Install the new fan motor in the reverse order of the removal procedure.
- 8) Replace the panels in their correct positions.
- 9) Plug in the ice dispenser or connect the power source.

## **15. GEAR MOTOR**

- 1) Press the push button to dispense all the ice in the storage bin.
- 2) Remove the front panels (upper) and (lower), and turn off the power switch.
- 3) Remove the four machine screws securing the motor bracket, and take off the gear motor together with the auger.
- 4) Take off the motor cover, and remove the three machine screws securing the ice guide.
- 5) Move the ice guide toward the auger, and remove the spring pin connecting the auger and joint.
- 6) Remove the four machine screws securing the gear motor, and pull out the gear motor.
- 7) To refit the gear motor, reverse the above procedure. Check for proper operation.

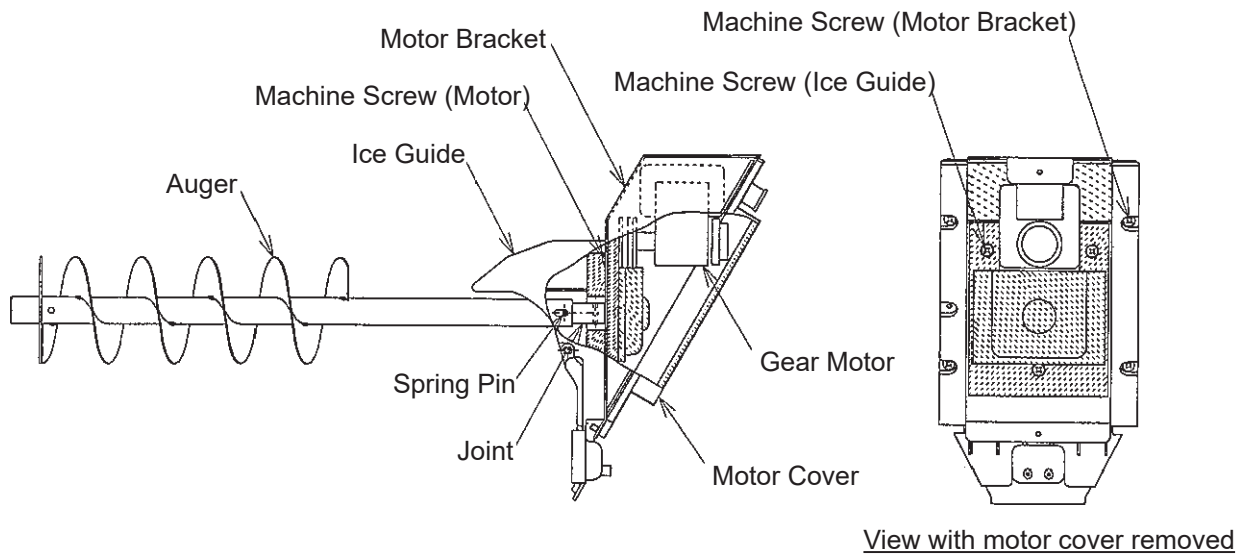

**Fig. 17**

## 16. BIN CONTROL SWITCH

- 1) insert a flat blade screwdriver between the switch case and switch base, and lightly pry the switch case off.
- 2) Use a phillips screwdriver to loosen the screw securing the microswitch and remove the u-nut.
- 3) To refit the microswitch, fit the mounting holes of the microswitch and switch base, and secure them with the u-nut.
- 4) To refit the switch base, put the switch case shaft (left) into the left side mounting hole in the switch base. Use the u-notch on the switch base to thrust the switch case shaft (right) into the right side mounting hole in the switch base.

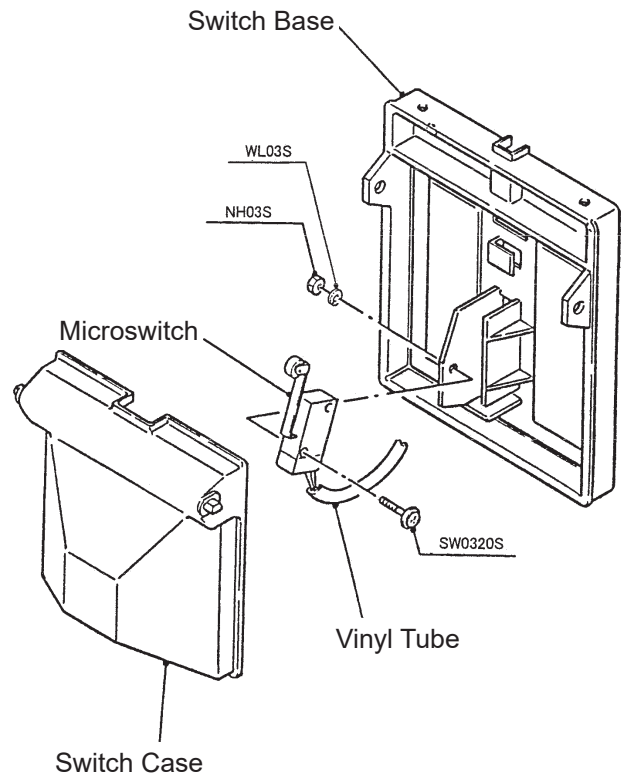

**Fig. 18**

## 17. PUSH BUTTON SWITCH AND PILOT LAMP

- 1) Unplug the ice dispenser.
- 2) Remove the front panel (upper) and front panel (lower).

If the push button switch does not require replacement, skip 3) - 11).

- 3) Remove the connectors to the push button switch.

- 4) Loosen the nut on the housing screw.

- 5) Turn the push button switch counterclockwise, and remove the push button.

- 6) Remove the supporter on the back of the push button.

- 7) Turn the stopper counterclockwise, and remove it from the housing screw. Detach the push button switch from the ice station.

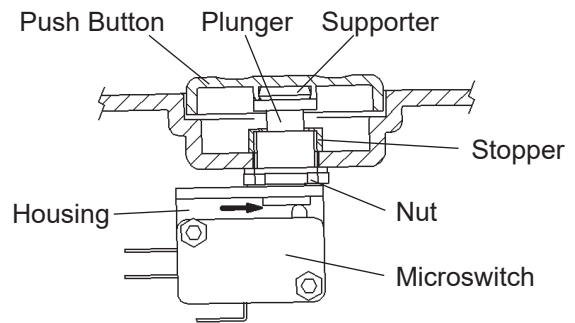

**Fig. 19**

- 8) Remove the supporter from the new push button switch. Fit the housing screw into the hole on the ice station, and attach the stopper to the end of the housing screw.

- 9) Loosen the nut on the housing screw.

- 10) Attach the supporter to the end of the plunger.

- 11) Fit the push button while retaining the plunger in place between the plunger and the microswitch with a flat blade screwdriver or the like.

If the pilot lamp does not require replacement, skip 12) - 14).

- 12) Cut the pilot lamp leads at the wire connectors.

- 13) Remove the pilot lamp.

- 14) Install the new pilot lamp.

- 15) Assemble the removed parts in the reverse order of which they were removed.

- 16) Plug in the ice dispenser.